

VOLVO DOWN UNDER

VOLVO P120 AMAZON - P1800 SPECIALISTS

CATALOGUE *for genuine & remanufactured*
VOLVO P1800 & 1800 ES SPARE PARTS

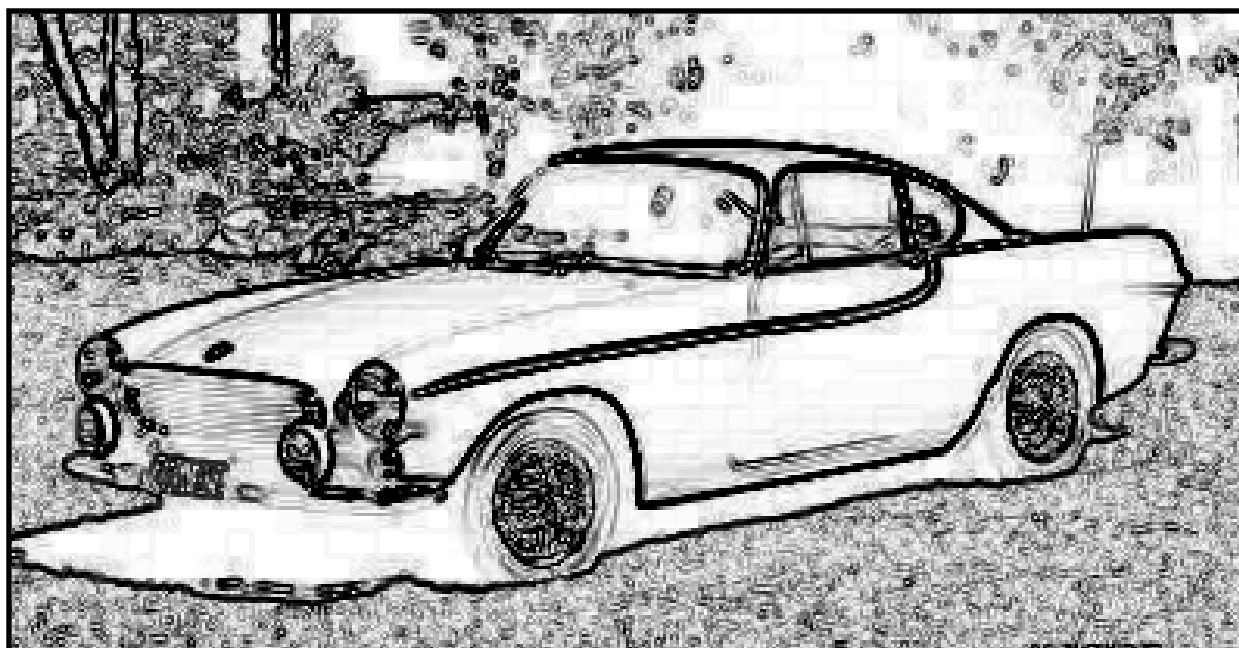

14 Cross Street
Pymble 2073 NSW
www.gerrylister.com
info@gerrylister.com

GST applicable to Australian sales only

419368	(1.) Inlet valve, B18	28.00
419292	(2.) Exhaust valve, B18	30.55
415424	(3.) Protector seal, above valves, B18	3.81 pc
415424-1	Protector seal set (8 pieces)	24.18 set
415266	(4.) Valve guide, B1 8 (inlet/exhaust)	12.22
415035	(5.) Valve collet, B18 (2 per valve)	3.82 pc
419639-R	(6.) Inlet valve, B20B (42 mm, std.)	28.00
419766	Inlet valve, late B20B/B20E/F (44 mm)	31.82
419640-R	(7.) Exhaust valve, B20B (35 mm, std.)	28.00
CNA-5406 (HD)	Exhaust valve, 37 mm (heavy duty)	47.09
419735	Exhaust valve, B20E/F	66.69
419702	(8.) Valve stem seal, B20 valves (R)	3.05
8291532	Hardened valve seat for lead-free conVn.	28 pc
419643	(9.) Valve collet, B20 (2 per valve)	3.82 pc
419652-R	(10.) Valve guide, B20, inlet	10.69
419653-R	(11.) Valve guide, B20, exhaust	10.69
418737	(12.) Valve spring, B18/B20 (genuine)	14 pc
418737 (D)	Double valve spring (competition use only)	53.45 pc
418737 (DB)	Washer for double valve spring	17.31 pc
418286	(13.) Tappet adjuster screw, B18/B20	10.18
921781	(14.) Lock nut, tappet adjuster	1.02
418297	(15.) Rocker arm bushing	11.71
418426	(16.) Spring (3 per car)	18.58
411140	(17.) Spring (2 per car)	Call

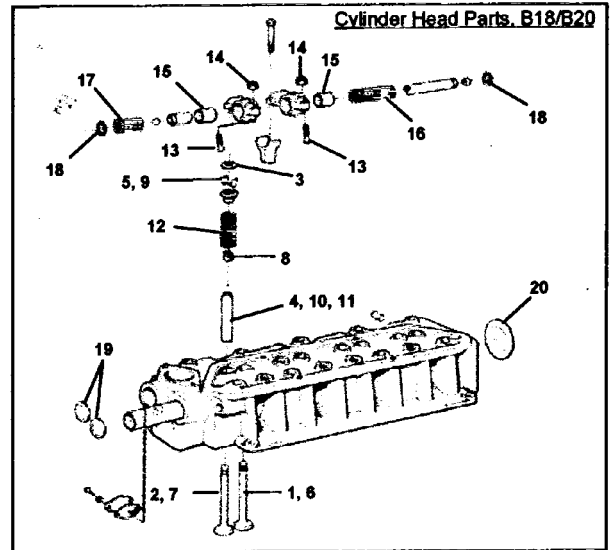

914456	(18.) Circlip	0.76
418717	(19.) Core plug (35 mm) (ref 463903)	4.58
418718	(20.) Core plug (45 mm) (ref* 463904)	4.58

275411	Head set, B1 8 (incl. manifold gasket) Elring	126.00
275411-1	Head set, B18 (incl. manifold gasket) (R)	98.00
275536	Head set, B20B (incl. manifold gasket) Elring	148.91
275560	Head set, B20E/B20F (genuine) (275560 does not include manifold gasket)	159.85

275439	Manifold gasket set, '61 --66 (ref- 270657)	44.55
275480	Manifold gasket set, 67269 (ref:271339)	44.55
271341	Manifold gasket set, B20E/F (genuine)	67.20
271341-1	Manifold gasket set, B20E/F (repro)	48.36

(these include manifold gasket + downpipe gasket)

270628	Bottom end set, B1 8/B20, gen. (ref 275494)	94.18
270628-1	Bottom end set, B1 8/B20 (repro)	67.45

275411/270628	Engine gasket set, B1 8 (genuine)	224.00
GaskB18	Engine gasket set, B1 8 (repro)	142.55
275536/270628	Engine gasket set, B20B (genuine)	235.45
GaskB20B	Engine gasket set, B20B (repro)	142.55
275560/270628	Engine gasket set, B20EIF (genuine)	240.55
GaskB20E/F	Engine gasket set, B20E/B20F (repro)	159.09

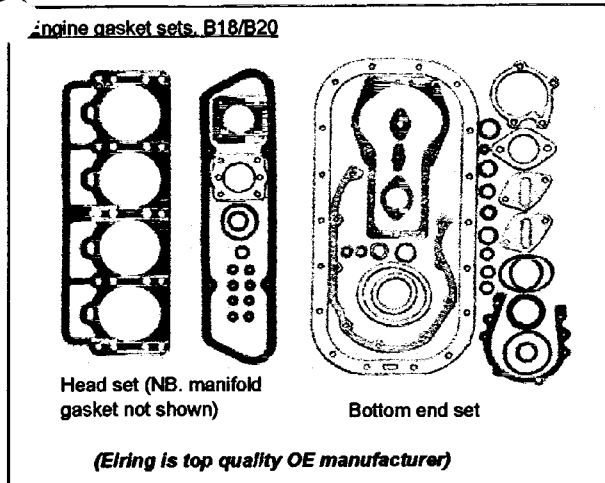

403515	(11.) Oil filler cap, without vent	44.55
418954	(2.) Oil filler cap, with vent	63.64
940096	(3.) Seal, under cap	4.58
419678	(4.) Rocker cover gasket, B18/B20	12.22
,0045	(5.) Screw for rocker cover (4 per car)	1.02 pc

41899D-R	(6.) Cylinder head gasket, B18 (Payen)	42.00
419310	Cylinder head gasket, B20B (genuine)	56.00
419310-R	Cylinder head gasket, B20B	42.00
419763	Cylinder head gasket, B20E	70.00
9139282	Cylinder head gasket, B20F (ref: 460322)	95.45
419310-HD	Cyl. head gask, B20 (steel reinf., to 2.2 liter)	129.82
191523	(7.) Bolt for cylinder head	10.69
418408	(8.) Guide sleeve	21.64
418717	(9.) Core plug (35 (ref: 463903)	4.58 pc
418718	(10.) Core plug (45 mm) (ref: 463904)	4.58 pc

418910-B	(11.) Inlet manifold, B18B (good 2nd-hand)	286.36
952075	(12.) Plug on manifold	8.65
418405	(13.) Exhaust manifold, B18B (Single downpipe)	397.09
419561	(14.) Inlet and exhaust manifold, B20B	700.00
418870	(15.) Manifold gasket, B18B/B20B (genuine)	31.82
419764	(15.) Manifold gasket, B20E/F (genuine)	56.00
953238	(16.) Manifold stud (38 mm)	3.82
953241	Manifold stud (45 mm)	3.82
953243	Manifold stud (50 mm)	3.82
955826	(17.) Nut for studs	0.76

419405	(18.) Hose, B18B '61-66 w. positive crank ventn.	Use
460003	Hose, B20 crankcase ventilation	26.73

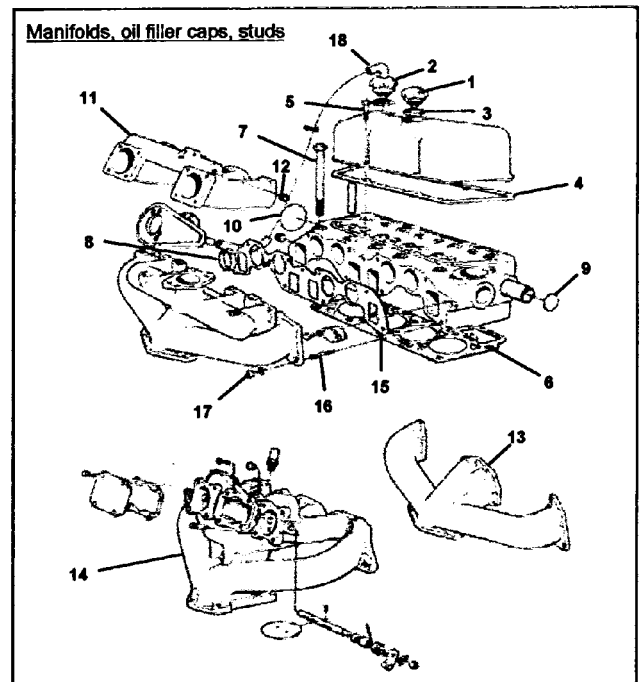

Camshafts. Cam followers (lifters):

(Note. now cams should always be fitted with new followers - and vice versa)

1218579	(1.) Camshaft, type "C" (genuine: ref 418707)	369.09
1218579-R	Camshaft, type "C" (R)	231.64
1218580	Camshaft, type "D" (genuine)	369.09

1218580-R	Camshaft, type "D" (R)	231.64
1218581-R	Camshaft, type "K" (R)	241.82

910118	(2.) Woodruff key for camshaft	6.36
418363	(3.) Spacer ring, behind camshaft	20.87

150169	(4.) Camshaft nut	16.55
--------	-------------------	-------

418423-1	(5.) Cam follower (repro)	18.58
----------	---------------------------	-------

NB: Warranty for cams and followers is only given when both items are purchased - and fitted - at the same time!

418304	(6.) Pushrod	Call
--------	--------------	------

430119	} 430119-1 } Camshaft bearing set, standard sizes	57.27
418249		
418250		

Camshaft Kits Onclude cam & 8 followers + assembly grease):

275762	Camshaft kit, type "C" (genuine)	470.91
275762-1	Camshaft kit, type "C" (R)	328.36
275763-1	Camshaft kit, type "D" (R)	328.36
275764-1	Camshaft kit, type "K" (R)	338.55

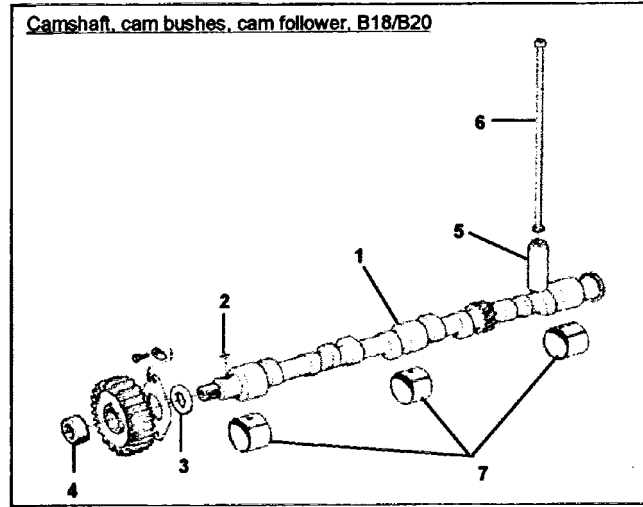

Timing gears, ancillaries and gear sets:

418272	(1.) Timing cover gasket (ref:1378907)	12.22
418622	(2.) Felt seal, in timing cover	7.64
418624	(3.) Circlip	16.55
418626	(4.) Retainer ring	10.69
419681	(5.) Thrust flange behind cam gear (bronze)	24.18
955512	(6.) Screw, early type	Use lock screw 943455
418422	(7.) Lock washer, early type	Use lock screw 943455
943455	(8.) Lock screw for thrust flange (2/car)	3.05 pc

270690-R	(9.) Timing gear set (fiber cam/crank gear only)	220.18
270690 (R)	Timing, gear set complete (fibre)	253.27
(NB. Crankshaft gear not shown in this illustration - see page 4)		
271944	Timing gear set (current genuine - all-steel)	369.09
271944D	Timing gears only, all -steel	318.18 pair

952075	(10.) Oilway plug	8.65
418416	(11.) Oil feed nipple	33.09

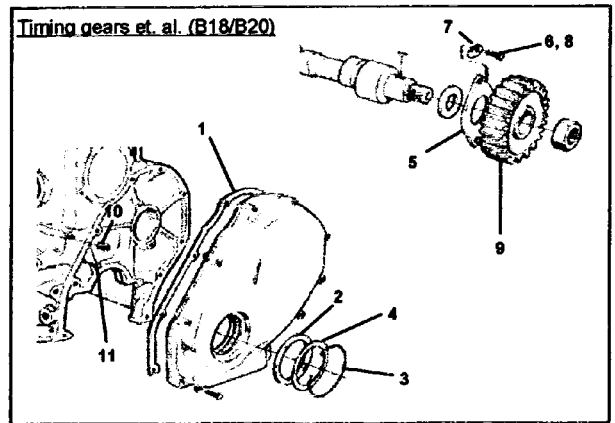

Oil Pump, Oil Filter, Sump Plug and Gasket:

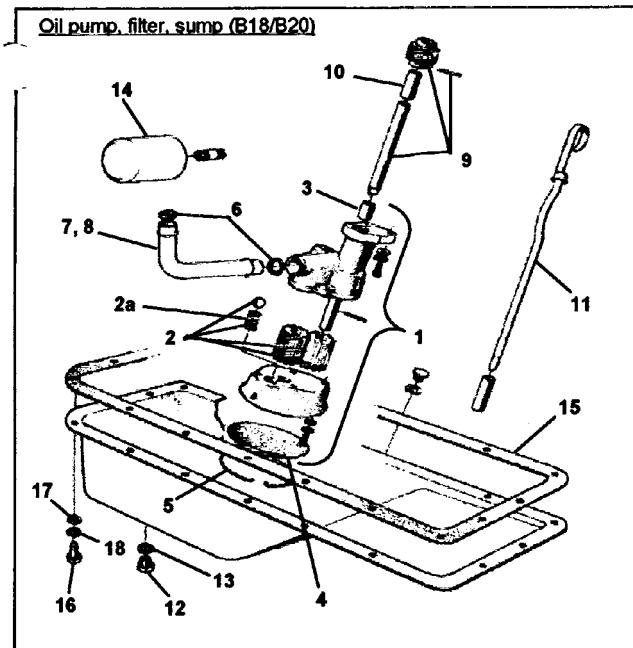

1218706	(AR) Oil pump, aluminium (as original)	199.82
1218706	(SR) Oil pump (all-steel, for competition use - USA)	248.18
RV-51 0	(2.) Repair Kit, for B20 type oil pump	82.73
430161	(2a.) Return spring, oil pump	10.18
18130	(3.) Bushing	9.16
418288	(4.) Strainer for oil pump	66.18
418289	(5.) Lock ring, for strainer	11.96
418360	(G.) Rubber seal for oil delivery pipe	6.36
418627	(7.) Oil delivery pipe, B18	Call
419539	(8.) Oil delivery pipe, B20	75.09

418277	(9.) Distributor drive gear	390.73
418277 (9)	(9.) Distributor drive gear (good used)	152.73

418251	(10.) Bush for drive gear	51.67
418643	(11.) Oil dipstick	Call
190798	(12.) Oil drain plug	8.15
18818	(13.) Copper gasket	2.29
672910-1	Oil pressure sender (repro)	11.20
418432	(14.) Oil filter (genuine)	19.09
418432-1	Oil filter (repro)	15.27

418262	(15.) Sump gasket	19.09
955523	(16.) Bolt for sump attachment (length = 16 mm)	0.76
955524	(16.) Bolt for sump attachment (length = 19 mm)	0.76
955894	(17.) Flat washer	0.51
941907	(18.) Curved spring washer	0.51

Pistons & Rings, Mountings, Seals (B18/B20)

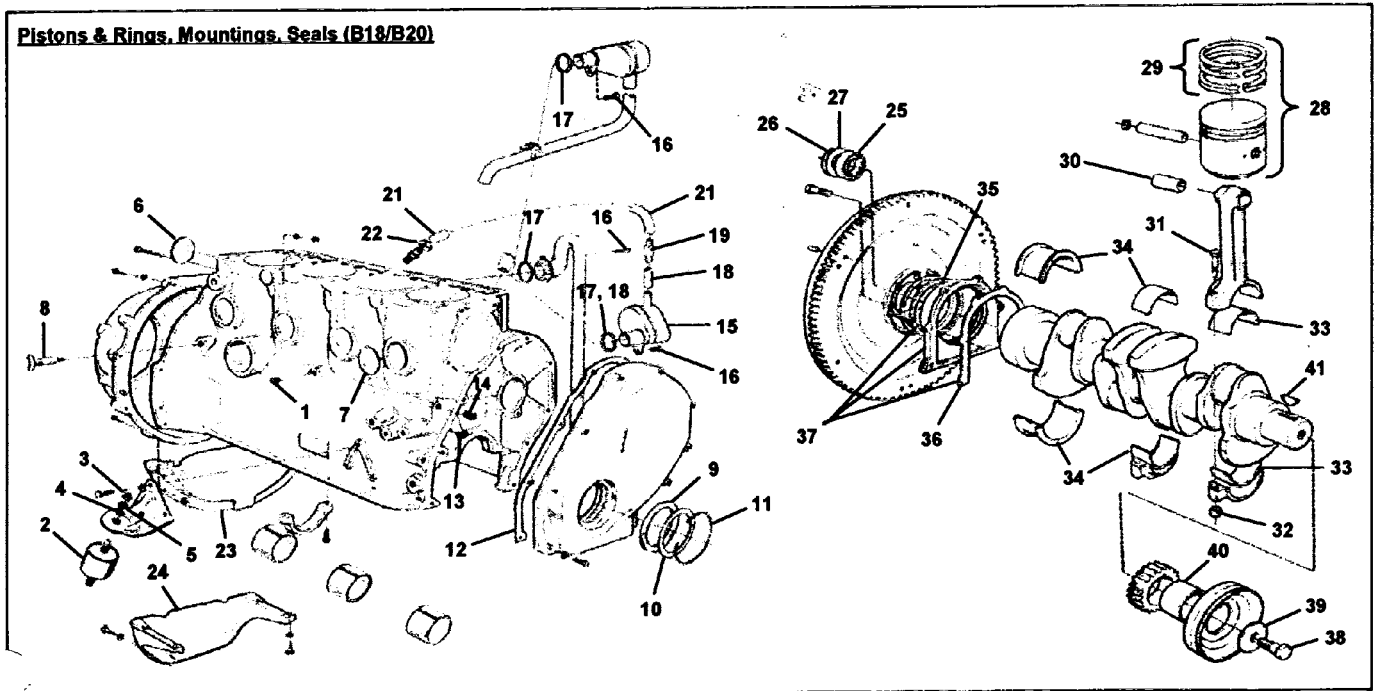

277016 (R)	Engine paint, red (250 ml can)	35.64	275195	Piston with rings, B18, + 0,030" (Mahle)	166.73
16218	(1.) Elbow union for oil pressure hose, '6/'69	22.91	275196	Piston with rings, B18, + 0,040" (Mahle)	166.73
419834	(1.) Elbow union (twin outlet), 70-73	Call	275282	(29.) Piston ring set, B18, std. (genuine)	157.82
666890	(2.) Engine mounting (genuine)	39.45 pc	275282 (R)	Piston ring set, B18, std.	142.55
940157	(3.) Nut for engine mounting	1.27 pc	275283	Piston ring set B18, + 0,020" (Perfect circle)	142.55
955896	(4.) Washer	0.51	275284	Piston ring set, B1 8, + 0,030" (genuine)	142.55
940110	(5.) Spring washer	1.02	275285(R)	Piston ring set B18, + 0,040"	159.09
663605-R	Gearbox mounting	28.00	275286	Piston ring set, B1 8, + 0,050"	252.00
418677	(6.) Core plug (42 -) (ref- 463902)	4.58 pc	272002	(28.) Piston w. rings, B20, std. (88,86-88,89 mm)	166.73
418718	(7.) Core plug (45 mm) (ref. 463904)	4.58 pc	272003	Piston w. rings, B20, std. 88,91 (Mahle)	166.73
82745	(8.) Drain cock on engine block	28.00	272012	Piston w. rings, B20, + 0,015" (Mahle)	166.73
418622	(9.) Felt seal, front	7.64	272004	Piston w. rings, B20, + 0,030" (Mahle)	166.73
418626	(10.) Retainer ring	10.69	272005	Piston w. rings, B20, + 0,040" (Mahle)	166.73
418624	(11.) Lock ring	16.55	275334	(29.) Piston ring set, B20, std. (genuine)	170.55
-418272	(12.) Gasket (ref. 1378907)	12.22	275334-R	Piston ring set, B20, std. (repl. 275306)	140.00
-418416	(13.) Oil feed nipple	33.09	275314-R	Piston ring set, B20, + 0,015"	140.00
952075	(14.) Oilway plug	8.65	275336-R	Piston ring set, B20, + 0,030" (275307)	140.00
419808	(15.) Breather (replaces 418906, use ring 418905)	96.73	418295	(30.) Small end bush (standard size)	21.38
955512	(16.) Screw	0.51	415223	(31.) Con rod bolt	NLA
418412	(17.) Sealing ring (early type di = 21)	3.56	191410	(32.) Nut	3.82
419805	(18.) Seating ring late B20 di = 26)	8.15	271051	(33.) Big end bearing set (standard size)	77.64
419422	(19.) Hose	16.29	271052	Bigendbearingset (-0.010")	67.45
418982	(20.) Valve	19.85	271053	Big end bearing set (- 0.020")	77.64
943706	(21.) Hose, crankcase ventilation, B1 8	36.91 pc	271214	(34.) Main end bearing set (standard size)	95.45
419446	T-piece (nipple) (not shown on illustration)	19.09	271215	Main end bearing set (0.010")	95.45
942928	(22.) Clip	4.58	271216	Main end bearing set (0.020")	95.45
942390	(21.) Hose, crankcase ventilation, B20	49.64 m	276701	Main end bearing set (0.030")	95.45
418353	(23.) Cover plate (early type, to 1966)	Call	-418621	(35.) Felt seal, rear (original old-style sealing)	7.64
419314	(24.) Cover plate (1967-, replaced by 463830)	Call	418257	(36.) Gasket for rear flange (now 430134)	7.64
11009	(25.) Gearbox input shaft support bearing (R)	14.00	1218634S	(37.) Crankshaft seal kit (oil seal type)	100.55
191848	(26.) Lock ring (now 6842797)	2.55	430118	This kit converts felt seal to modern style oil seal	19.09
418663	(27.) Cover plate	14.76	940111	(38.) Bolt for crankshaft pulley	3.82
VYM10115	Workshop manual (genuine), B1 8B/D engine	66.18	191688	(39.) Washer	8.65
			418264	(40.) Hub	113.27
			910123	(41.) Woodruff key	4.33
			9992405 (R)	Puller for crankshaft gear (R)	47.09

(Note. Pistons are sold in singles: ring sets are for 1 engine)
 275193 (28.) Piston with rings, B18, std. (Mahle) 166.73
 275194 Piston with rings, B18, + 0,020" (Mahle) 166.73

Tank, Filler Cap & Fuel hose to and from Pump

958236	Screw for tank fitting to body	0.76 pc	1336184	Fuel pump, B18/B20 (genuine)	91.63
954336	Screw union, fuel pipe to fuel tank	16.55	1336184-1	Fuel pump, B18/B20 (repro)	67.45
673496	Tank sender unit (1961-1969)	286.36	460678.00	Plastic spacer pump/engine (ret 301002)	18.83
665160	Seal for sender unit	7.13	1378905.00	Gasket, against engine block (2/car)	2.80 pc
950010	Screw for sender unit (6 per car)	0.51 pc			
664287	Filler cap, with hinge (R)	Call			
665118	Rubber seal under filler cap	24.18			
954305	Fuel pipe under car (bundy pipe)	27.65/m			
954322	Union (cap) nut for metal fuel pipe	7.15			
419796	Fuel hose, in front of pump (65-70) (R)	8.15/m			
419797	Fuel hose, pump to carburettor (65/70) (R)	6.87/m			
Fuel pump, with glass bowl type AC (234008).1961-1964					
234008	Fuel pump (BI 8)	NLA			
CVI-ACI	Union, to use pump with rubber fuel hose	13.24 pc			
61942	(1.) Diaphragm (genuine)	62.36			
73580	(2.) Valve (2 per pump)	16.55 pc			
73582	(3.) Gasket under valve (double: 1 per pump)	3.56			
15517	(3.) Gasket, under valve (single: 2 per pump)	2.55 pc			
18780	(4) Gasket under glass bowl (cork type)	5.09			
190633	(4) Gasket under glass bowl (rubber type)	5.09			
1378905	Gasket against engine block (2/car)	2.80 pc			
276223	Repair kit (with instruction sheet)	78.91			
73537	(5.) Strainer	See 276224			
234002/3	(7/8.) Sealretainer	See 276224			
61945	(9.) Lever	See 276224			
529	(10.) Shaft	See 276224			
498	(11.) Lock ring (2 per pump)	See 276224			
61947	(12.) Washer	See 276224			
61949	(13.) Spring	See 276224			
276224	Overhaul kit (276223 + above items)	133.64			
460678	Plastic spacer pump/engine (ref 301002)	18.84			
73575	(14.) Glass bowl	40.73			
73539	(15.) Brace, for glass bowl	62.36			
64757 (R)	Fuel hose (braided), between pipe & pump	73.82			
954336	Union, on front of pump	16.55			

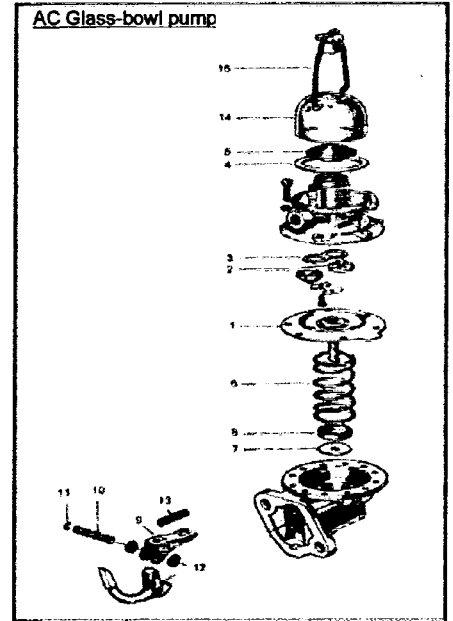

Fuel Pump, type AC (419291) (mixed with Pierbura/65/69):

419427	(1.) Fiber washer	See 276281
419428	(2.) Seal under lid	See 276281
D-419291	(3.) Strainer (NB. Not included in 276281)	12.73
73580	(4.) Diaphragm	36.91
15517	(5) Valve (2 per pump)	16.54 pc
	(6.) Gasket, under valve	2.54 pc
	(7/8.) Seal/washer, under spring	See 276281
1378905	Gasket, against engine block (2/car)	2.80 pc
276281	Repair kit for 419291 (nos. 1, 2, 4-8)	49.64

AC

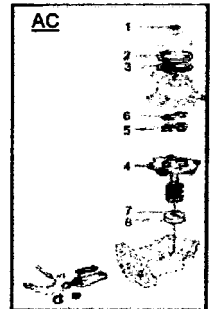
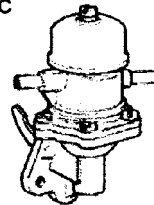

Fuel Pump, typ-e-Pierbura (418878, marked -"APG"- - mixed-with AC65-'69):

15521	(1.) Fiber washer	See 276520
418948	(2.) Gasket, under lid	5.09
418946	(3.) Strainer	Call
956078	(4) Screw	0.76 pc
955918	(5.) Spring washer	0.51 pc
D-418878	(6.) Diaphragm (with spring, seal, retainer)	39.45
1378905	Gasket, against engine block (2/car)	2.80 pc
276520	Repair kit for 418878 (nos. 1, 2, 4 5, 6)	53.45

APG

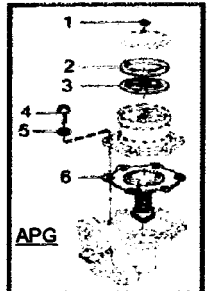
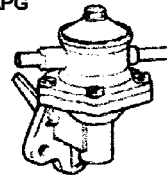

Fuel pump, type Pierbura (460429.-marked "APG"), late 1969.

All that is marked "S"	Fiber washer, under lid screw	See kit
	Screw	See kit
	Filter gauze	See kit
	Gasket under lid	See kit
276303	Repair kit for 460429	100.55
1378905	Gasket against engine block (2/car)	2.80 pc

APG

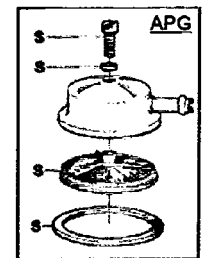
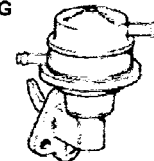

Fuel pump, current genuine for B18IB20 (Pierbura)::

Price

New SU carburetors:

237244/45(R)	SU HS6 (B18D) (NB. 3-bolt filter: state needle)	1336.36 pair
237256/57(R)	SUHS6(B18B) KD" needles: 1967-'68)	1336.36 pair
237418/19 (R)	SU HS6 (B20B)	1336.36 pair

237244/45 (ER) Rebuilt carburetors, exchange (2-bolt filter) 4750 pair
 (These marked ER are factory rebuilt carbs to concours standard)
 (Please note! We must have your carbs in exchange)

SU-GP 18 Gasket set, for 2 carburetors 36.91

237103	(1.) Needle TZ	(Paper filter, 100 bhp)	135
237221	(1.) Needle ZH	(Paper filter, 108 bhp)	130
237248	(1.) Needle KD	(Paper filter 1967, 115 bhp)	130
237255	(1.) Needle KF	(Silencing filter 67,115 bhp)	135
237353	(1.) Needle KN	(132013 1969, RHD only)	165 (spring-loaded)

237315	(1.) Needle DX	(USA exhaust emission)	145
237186	(2.) Jet (front), complete		48.36
237187	(2.) Jet (rear), complete		48.36
237188	(3.) Rubber seal, on jet		2.55 pc
237192	(4.) Needle valve and seat		36.91 pc
276278+	Service kit (2 carbs (excls. needles)		162.91 pair

94	(5.) Throttle spindle		35.64
237109	(6.) Throttle disc (can be used even on B20B)		29.27
237424	(7.) Throttle disc, B20B genuine (emission)		75.35
71849	(8.) Screw, disc to spindle 2 per spindle		1.78
907174	(9.) Lock pin		2.80
276292	Throttle spindle kit, with bushes (for 2 carbs.)		147.64 pair
2762781292	Overhaul kit, 2 carbs. (excls. needles)		225.27 pair

237082	(11.) Adjuster nut, B18 carburettor		12.73
237330	(11.) Adjuster nut, B20 carburettor		21.64

CM-1341	Jet bearing kit B18 (nos. 1044)		35.64
CVI-1442	Jet bearing ldt, B20 (nos. 1044)		47.09

1129629 Dashpot oil (SU genuine: 125 ml bottle) 16.55

237144	(15.) Dashpot lid (damper)		38.18
190349	(16.) Gasket		2.04
237084	(17.) Screw, vacuum chamber lid		2.04

71816	(18.) Piston return spring		14.76
237105	(19.) Lock screw, for needle (B18)		4.07
-I237422	(19.) Lock screw, for needle (B20)		5.09

-47457	(20.) Float(ref: 237216)		36.91
131016	(21.) Float pin		2.55
237131	(22.) Baffle		3.05
237214/215	(23.) Float chamber Lid valve/float (front/rear), B18		113.27 pc
237195/196	(24.) Float chamber Lid valve/float (front/rear), B20		113.27 pc
237106	(25.) Gasket, under lid		1.53

CHOKE CONTROL

55192	(1.) Inner choke cable		7.13 m
88783	(2.) Outer spiral		12.73 m
664425	(3.) Rubber grommet, LHD (holds cables together)		8.15

55192D (4.) Choke cable twin carbs (inner & outer) 49.64

237178	(5.) Clamp, outer choke spiral (to 1966)		14.00
237168	(6.) Ferrule, for choke cable		11.45
419452	Clamp (67/69)		6.36

418561/950003 Retainer/screw, for choke cable (7/8.) 36

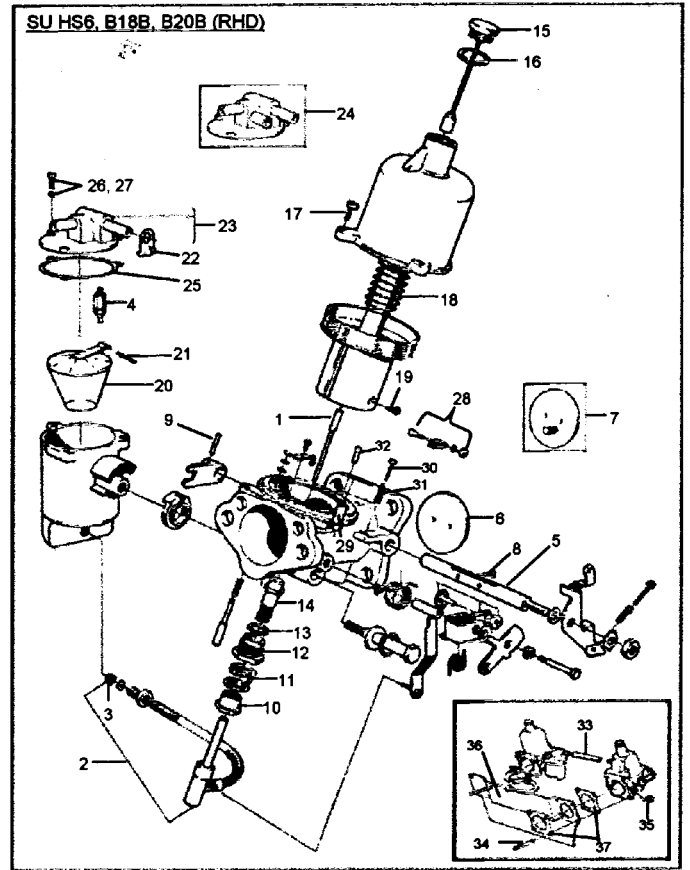

14185	(26.) Screw, float chamber lid (concours)		2.04
955918	(27.) Spring washer		0.51

237178	(28.) Clamp, outer choke spiral (to 1966)		14.00
237168	(29.) Ferrule, for choke cable		11.45

237085/71856	Adjuster screw/spring idle/choke (30/31.)		5.60
237104	(32.) Nipple Vacuum advance pipe (early cars)		14.00
419797	(33.) Hose, between carbs. (80 mm) (R)		2.55

953236	(34.) Pin stud, on inlet manifold, B18D (8/car)		2.55
955826	(35.) Nut (for 953236)		0.76

418512	(36.) Heat shield, under carbs. (B18)		Call
418754	(37.) Gasket, either side of shield '61-70 (4/car)		1.78 pc

419251 Shield, throttle linkage, wintertime, 266 56.00

SU 670 Tool Kit, Su carbs (mixture adjustment + needle valve removal tool) 36.91

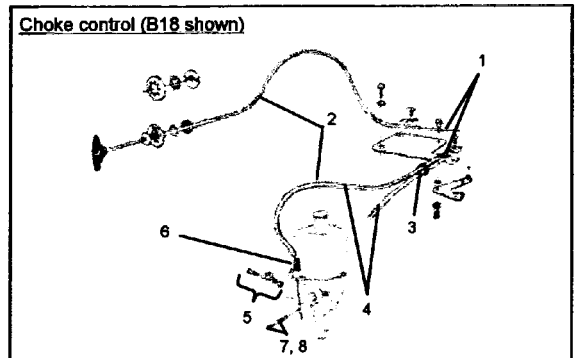

AIR FILTERS, SU CARBURETTORS:

LHD 1961-66		Price
73606 (R)	(1.) Air filter, for LHD cars 1961-1966	28 pc
73606 (CR)	(1.) Air filter, Volvo blue with decal	47.09 pc
FK-73606	Fitting kit, for 2 filters (excl. gaskets)	6.36 pc
418447	(2.) Gasket	3.82 pc
1006	Decal sticker (AC type) for filter 73606	5.09 pc
RHD 1961-1966:		
667583	(3.) Insert, for RHD filters, 1961-1966	28 pc
192015	(4.) Butterfly nut (& washer) for outer cover	5.09 per filter
1007	Sticker/decals (Coopers) for RHD filters	8.91 pc
LHD & RHD 1"7-1		
672280/81 -R	Air Filter (paired), 1967-1968 (5.+6.)	63.34 pair
955530	(7.) Bolt, for ftng of filter	2.55 pc
941907	(8.) Spring washer	0.51 pc
677607	(9.) Gasket	3.82 pc
1010	Decalslicker (AC type), for filters 672280/81	8.00
679658	(10.) Air filter insert (late B1 8) (genuine)	42.00
679658-R	(10.) Air filter insert gate B1 8) (repro)	36.91
680743	(11.) Filter housing, upper part	95.45
684042	(12.) Shutter housing, with thermostal	89.09
944405	(13.) Pre-heater hose	21.64
677607	(14.) Gasket	3.82 pc

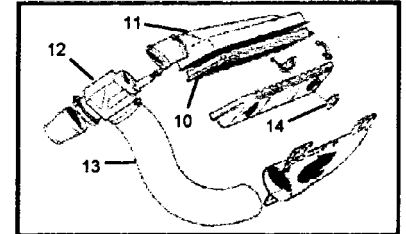
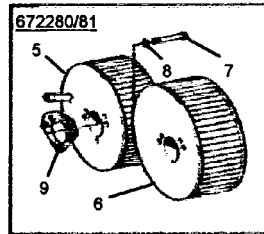
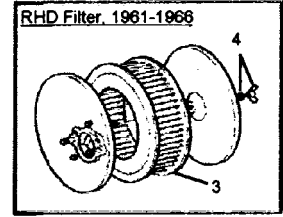
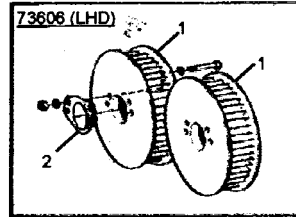

Ram pipe filters stocked for all SU carbs.

280 pair

THROTTLE LINKAGE FOR CARBURETTOR SYSTEM

LHD up to ch. no 9999:

653218	(1.) Rubber dust excluder	24.18
665563	(2.) Ball joint, with ball and nut	Call
418449	(3.) Intermediate shaft, ch. no. 1-16499	76.62
959093	(4.) Lock brace for ball-joint	2.55
666143	(5.) Bush (from ch. no. ch 483-)	8.91
418506	(6.) Anchorage	call
955512	(7.) Screw (2/car)	0.51 pc
940155	(8.) Washer	0.51 pc
668558 (R)	(9.) Lever (front)	16.55
668559 (R)	(10.) Lever (rear)	16.55
418963	(11.) Return spring on carb. lever (2/car)	7.64 pc

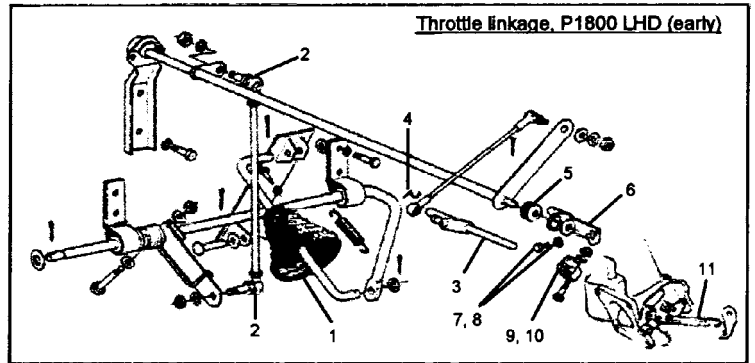

LHID. (ft. ch nr. 1100004, all RHD WORM:

661996-R	(1.) Accelerator pedal	70.00
955140	(2.) Shaft	NLA
	(3.) Screw	Call
3052	(4.) Rubber grommet	18.84
0.8506	(5.) Anchorage (earlier type)	Call
955512	(6.) Screw (2/car)	0.51 pc
940155	(7.) Washer	0.51 pc
666143	(8.) Bush	8.91 pc
959088(R)*	(9.) Ball-joint, with ball/brace (4/car)	14.76 pc
959093*	(10.) Brace	2.55
959094R*	(11.) Ball, on shaft (with fixing nut)	See 959088
955780	(12.) Nut	0.51
955637	(13.) Screw	0.76 pc
955893	(14.) Washer	0.51 pc
955920	(15.) Spring washer	0.51 pc
662006	(16.) Main shaft, ch. 10000 - 16499	Call
671950	(17.) Main shaft, ch. 16500 - slutet pA B1 8	Call
191203	(18.) Control rod	16.04
418449	(19.) 1 ntermediate shaft, ch 1-16499	76.62
419575	(20.) Intermediate shaft, ch 16500-	Call
668558(R)	(21.) Lever (front)	16.55
668559(R)	(22.) Lever (rear)	16.55
418963	(23.) Return spring (B18 + B20B RHD)	7.64 pc

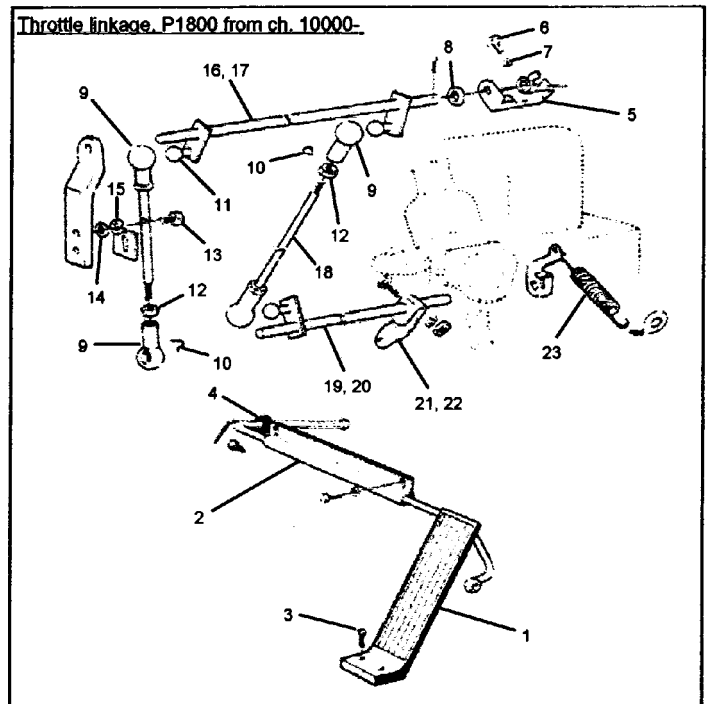

Price

237348/49	Stromberg 175 CD, front/rear (LHD)	Call
237350	(1.) Needle	49.64 pc
237437/38	Stromberg 175 CD (replaced 237348/49)	Call
237442	(1.) Needle	49.64 pc
276295	Gasket & lock washer kit 271474	40.22/carb.
237572	(2.) Jet	39.45
237566	(3.) Diaphragm, genuine (hydrin based)	14.00
237566(R)	(3.) Diaphragm, repro (nitrile based)	3.82
237567	(4.) Needle valve (with filter)	53.45 pc
820352	(5.) Screw & lock washer, vacuum chamber lid	2.04 pc
276295-2	Service kit, 2 carbs. (excludes neecffes)	201.09 pair
237359/60	(6.) Throttle spindle (front/rear)	36.91 pc
237272	(7.) Throttle disc	30.55 pc
71693	(8.) Screw, disc to spindle	2.29 pc
CM-001	Bushes, for throttle spindle in carb. body	19.09 pc
276300	Throttle spindle, kit (for both carbs.)	Call
2762951300	Overhaul kit (both carbs, needles excl.)	291.45 pair
237473	(12.) Dashpot fid (damper)	53.45
--" 17427	(13.) Gasket	6.87
/358	(14.) Piston return spring	28.00
237292	(15.) Float	58.55
237293	(16.) Float pin	10.69
237374	(17.) Bypass valve, complete	118.62 pc
276309	(18.) Bypass valve diaphragm kit	35.64
237474	(19.) Temperature compensator	133.64
237573/74	(20.) Lid (with screws), for temp. compensator	28.00
237380	(21.) Adjuster screw, by temp. compensator	14.00
237381	(22.) Spring, for adjuster screw	2.80
237286	(23.) Throttle stop screw	10.69
237469	(24.) Spring, for throttle stop screw	4.58
237284	(25.) Clamp for (outer) choke cable	4.33
953237	(26.) Pin stud, under carburettor	2.55 pc
955826	(27.) Nut	0.76 pc
419744	(28.) Heat shield (2/car)	28 pc
418754	(29.) Gasket (4/car)	1.78 pc

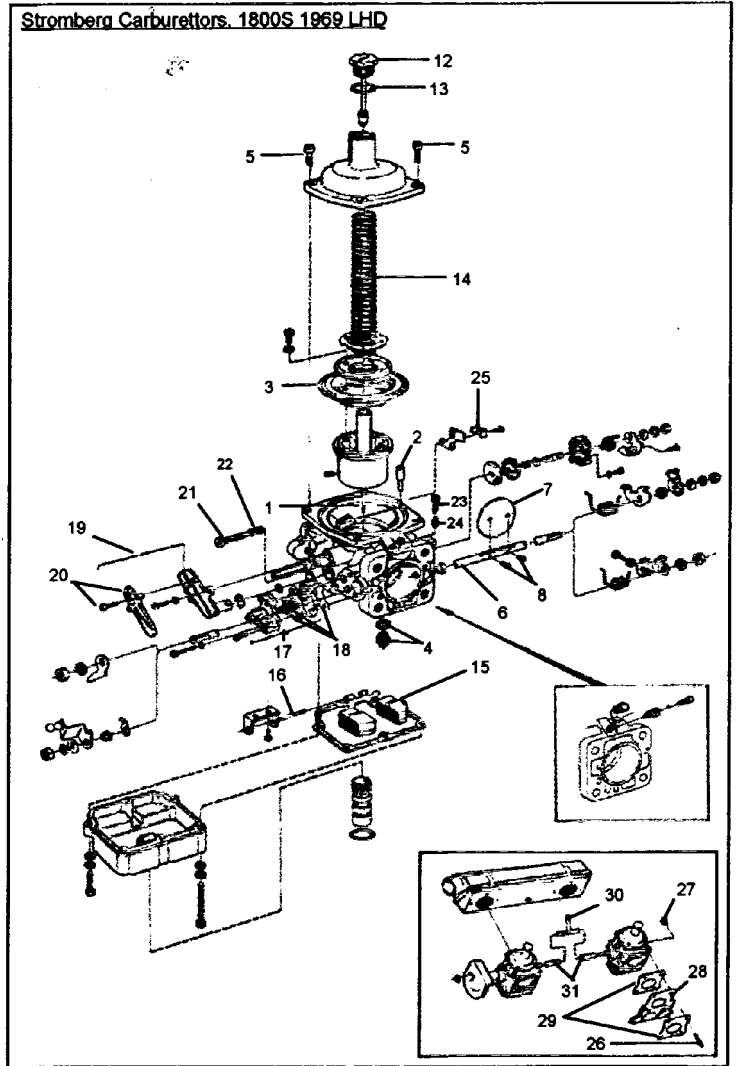

943508	(30.) T-junchon	28.00
419797	(31.) Fuelhose (55mmx2) (R)	3.82 pair

Air filter, 1800S (B20B, LHD & RHD)

Price

679658	(1.) Air filter element, B20B (genuine)	42.00
679658-R	(1.) Air fitter element, B20B (repro-)	36.91
680743	(2.) Filter housing, upper part	95.45
680642	(3.) Gasket	4.07
955523	(4.) Bolt (6/car)	0.76
941907	(5.) Spring washer (6/car)	0.51
679623	(6.) Clamp (4/car)	9.67 pc
673792	(7.) Brace (4/car)	6.36 pc

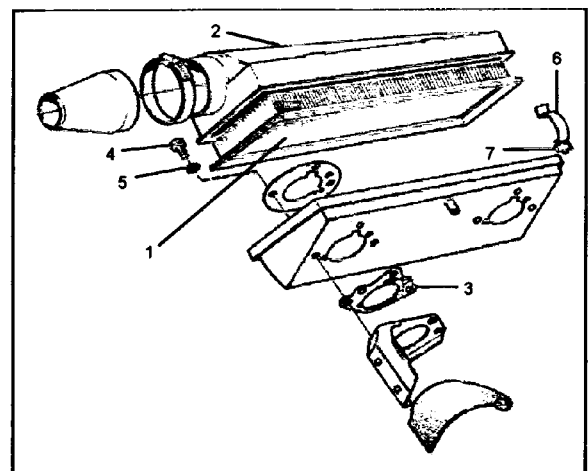

Price

682149	Fuel tank sender unit (1970 -1973)	171.82	683936	Fuel filler flap, with hinge/seal seat	282.55
665160	Gasket for sender unit	7.13	683564	Rubber seal for flap	35.64
950010	Screw for sender unit (6 per car)	0.51 pc	664738	Lock, with chrome housing & 2 keys	72.55
			664735	Lock cylinder only, with 2 keys	53.45
241723	Fuel pump, 1800E to ch 37549	556.18			
241724	Fuel filter, 1970 - 1971	75.09	682126	Cable (1800E (all), 1800ES 1972)	87.82
460900	Fuel pump, 1800E ch 37550 -, all ES	674.55	1212152	Cable (1800ES 1973)	Can be produced
243214	Fuel filter for above, genuine	NLA	418963	Spring	7.64
243214-R	Fuel filter	57.27	460560	Return spring	5.60

Fuel injection wiring harnesses

See page 11

Rubber Protectors on Iniection Hamess

943693*	Rubber protector, inj. harness, 2 pin	11.45 pc
945783*	Rubber protector, 3 pin (NB. 3 pin is biggest)	33.09 pc
943695*	Rubber protector, 4 pin	24.18 pc
943690-1*	*Set of rubber protectors (7 x 2-pin, 2 x 4-pin, 1 x 3-pin)	100.55 set

**Protector (injection harness)
(2 pin, 3 pin or 4 pin)**

683472 (R)	(1.) Air filter element	53.45
192354	(2.) Wing nut	Call
682043	(3.) Hose	28.00
951797	(4.) Hose clamp	4.84 pc

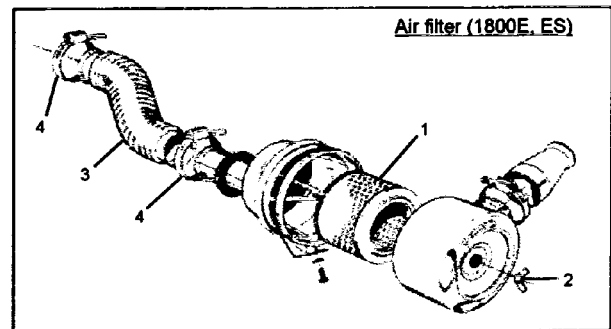

461674	Injector, 1800E/ES (ref 241720 & 462645)	327.09 pc
419784	Seal (Large) under injector	3.05 pc
419785	Seal (small) under injector	3.05 pc

Price

**FURTHER INJECTION PARTS WILL APPEAR IN
A LATER EDITION OF THIS CATALOGUE**

Cooling System. 1961-1966:

		Price
271602	(1.) Water pump kit (with gasket, seals, bolts)	222.73
271602-R	Water pump kit, repro.	95.45
275540	(2.) Gasket set (B18/B20B/B20E)	14.76
960282	(3.) Fan beft (B18 LHD/RHD, (B20 LHD))	14.00
418496-R	(4.) Thermostat (78 degrees)	21.64
419693	(4.) Thermostat (82 degrees, Wahle	24.18
273342	(4.) Thermostat kit, with seal (82 deg. Wahler)	26.73
1218680	(4.) Thermostat (88 degrees, Wahle	24.18
460579	(4.) Thermostat (92 degrees)	24.18
273277	(4.) Thermostat kit, with seal (92 degrees)	26.73
418361	(5.) Rubber seal for thermostat	2.55
418325	(6.) Aluminium housing, for thermostat (A 966)	70.00
FK-004	Fitting kit for aluminium housing	1.78 set
252086	(7.) Radiator	Call
1013	Decal (sticker) for radiator'6166	5.09
87502	(8.) Drain cock	48.62
87842	(9.) Radiator cap, -1966 (current genuine)	28.00
657876	(10.) Radiator hose, upper	28.00
952659	(11.) Hose clamp, upper, to ch. no. 19174	3.05 pc
652072	(12.) Radiator hose, lower (cars with oil cooler)	78.91
653031	Radiator hose, lower (cars without oil cooler)	17.82
952659	(13.) Hose clamp, lower, to ch. no. 19174	3.05 pc
951789	(14.) Hose clamp, inner lower, to ch. 19174	3.05 pc
418334	(14a.) Water inlet pipe	82.73

Cooling System-1967-1973:

271602	(1.) Water pump kit (with gasket, seals, bolts)	222.73
271602-R	Water pump kit, repro.	95.45
460531-1	(1a.) Clutch flange, fbrB20waterpumps (R)	82.73
275540	(2.) Gasket set (BI 8/B20B/B20E)	14.76
960282	(3.) Fan beft, all B1 8 but B20 LHD only	14.00
419419	(3.) Fan beft (RHD cars, B20)	16.55
418496-R	(4.) Thermostat (78 degrees)	21.64
419693	(4.) Thermostat (82 degrees, Wahle	24.18
273342	(4.) Thermostat ldt, with seal (82 deg. Wahler)	26.73
1218680	(4.) Thermostat (88 degrees, Wahle	24.18
460579	(4.) Thermostat (92 degrees)	21.64
3277	(4.) Thermostat kit, with seal (92 degrees)	26.73
8361	(5.) Rubber seal for thermostat	2.55
,9333	(6.) Aluminium housing (1967-1973)	69.75
FK-004	Fitting kit for alurrinium housing	1.78 set
252111	(7.) Radiator (brand new coming soon)	Call
461646	(8.) Radiator cap	19.09
1018	Decal sticker for radiator cap	6.36
460438	(8a.) Water inlet pipe (B20F only - USA)	88.58
672703	(8b.) Fan (alt. 2, early production)	112.00
672740	(8c.) Washer (for use with fan 672703)	36.91
676556	Radiator hoses an radiator hose Kits	
952663	(9.) Radiator hose, upper (B18 ch. 19175, B20B)	17.82
273190	(10.) Hose clamp for 676556 (2 per hose)	3.05 pc
	Radiator hose kit (676556 + damps)	21.64
671840	(11.) Radiator hose, lower (B1 8, from ch. 19175)	110.73
952659	(12.) Hose clamp, fbr 671840	3.05 pc
952663	(13.) Hose clamp, for 671840	3.05 pc
673196	Radiator hose, lower (B20B, 1969)	17.82
951791/92	Hose clamps, for 673196 (1 of each)	5.09 pair
273191	Radiator hose ldt (673196 + clamps)	21.64
273193	Radiator hose kit, upper (B20E, B20F)	3.82

B18, 1961-1966 (up to ch. 19174)

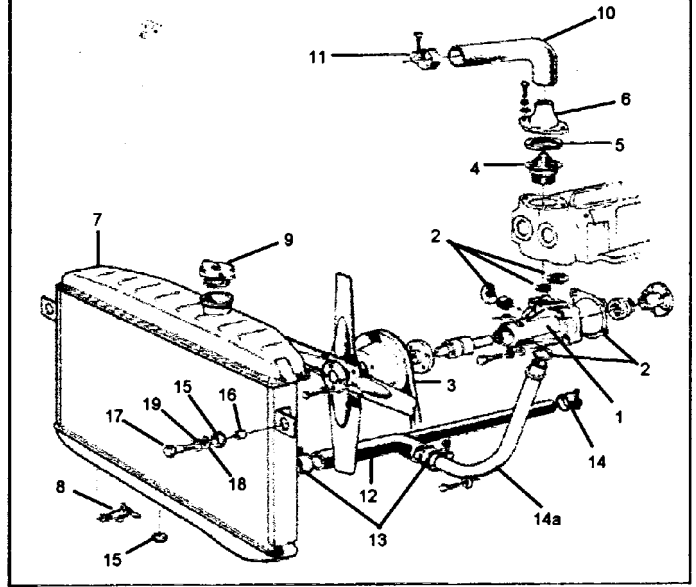

Radiator fitting-parts (both types) :

		Price
673989	(15.) Rubber bush (3/radiator)	4.07
663497	(16.) Sleeve, from ch 19175 (2/radiator)	16.03
955675	(17.) Fixing bolt, up to 1969 (2/radiator)	0.76
940115	(17.) Fixing bolt, (B20E/F) (2/radiator)	0.76
960148	(18.) Washer (2/radiator)	0.51
955950	(19.) Lock washer (2/radiator)	0.51

B18 from ch. 19175, B20

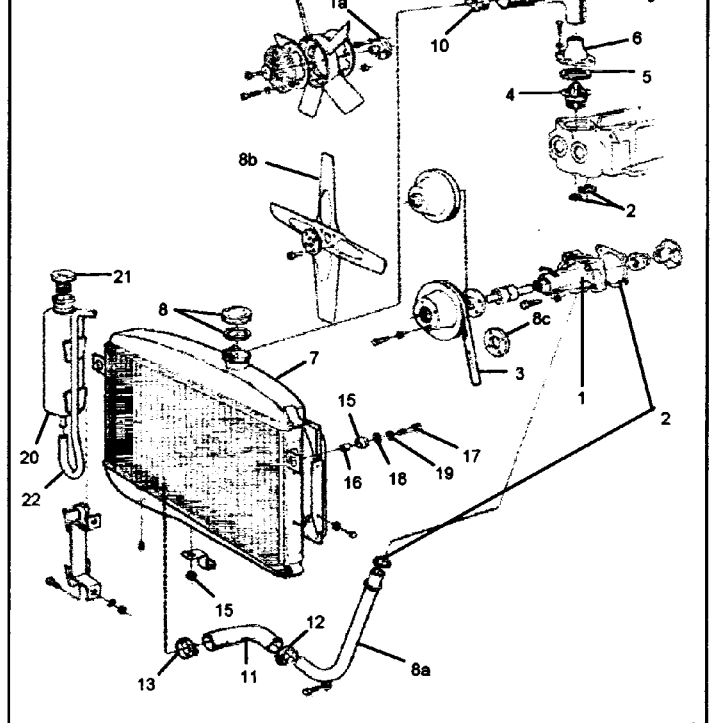

273194	Radiator hose kit, lower, B20E/F	36.65
676558	(20.) Expansion tank (B18) Qongneck	Use 686833
673336	(21.) Cap for exp. tank (B1 8) (Round with decal)	33.09
686833	(20.) Expansion tank (B20) (short neck)	82.73
673233	(21.) Cap for exp. tank (B20) (Round with-decal)	30.55
942700	(22.) Hose, expansion tank to radiator	7.64
1019	Decalsticker, for expansion tank cap	6.36

		Price			
238731/239447	Distributor, B1 8B, up to 1963 1/2	Call	243632	Distributor cap, B20B (Bosch genuine)	34.36
240208 (ER)	Distributor, B18B64-68	496.36	241659	Spring clip set for distributor cap	4.07 pair
241298 (ER)	Distributor, late B18B	496.36	238258	Rotor arm, B1 8 to 1964	33.09
241530 (ER)	Distributor, B20B	496.36	243903	Rotor arm, 1965-173	15.78
241719/243184	Distributor, B20E/F, early (repl. by 243314)	Call	241397	Condenser, B18	21.64
NB. All distributors (ER) are professionally overhauled: & sold on exchange)					
243314	Distributor, B20E/F, later type	2017.27	241650	Condenser, B20B	24.18
243314 (ER)	Distributor, B20E/F, exchange overhauled	Call	243013	Condenser, B20E	28.00
243276	Vacuum advance, for 243184 & 243314	78.91	238859	Contact breaker points- B18 ('64)	16.80
976733	Hose for vacuum advance	23.67 pc	240149	Contact breaker points, B 1 8B/D, '65-'68	19.09
243761	Condensate trap, for 241530 & 241719	9.67	1306169	Contact breaker points, B20B, B20E	14.76
418265	Gasket, under distributor	2.16	271410	Spark plug set (genuine), B20E	Use 271411
240586	Small parts set for 241298 (now 241671)	47.09	271411	Spark plug set (genuine), 131 8B, B20B, B20E	39.45
233262	Bush (upper for distributor shafts not 243314)	16.04	275661	Ignition lead set, LHD (red)	
238850	Bush (lower)	13.24	275654	Ignition lead set, RHD (red)	70.00
240588	Screw Insulator set, for points & condenser	35.13	241850 (B)	Plug cap (angled 90 degrees), brown	6.11
955229	Screw, through housing (incl. in 240588)	0.51	241850(S)	Plug cap (angled 90 degrees), black	7.13
659	Spring clip set for distributor cap	4.07 pair	241605	Plug cap (resistor), straight (239240)	10.69
233836	Drive coupling, at distributor base	57.27	241607	Rubber seal, on cables at distributor end	5.09
233837	Lock pin for coupling	5.09	238641	Ignition coil, B18, LHD	
233838	Spring retainer for pin	Call	1009	Decal (sticker), B18 ignition coil (yellow)	5.09
870690	Distributor cap (Bosch genuine)	31.82	35254	Ignition coil, B20	(replacement)
418120	Cover on low tension lead (at distributor end)	3.82	673261	Ignition lock barrel, with 2 keys (B18)	100.55
<u>EXHAUST SYSTEM, P11800, B18/B20</u>					
For Carburettor system. 1961-1969					
667980	Single downpipe	56.00	673339	Key blank, B18 (for Neiman locks)	14.00
403546	Gasket for above	8.91	660140	Key blank for "Assa" locks (genuine)	24.18
671823	Twin downpipe, ft ch 16500-	159.09	682656	Steering & ignition lock, B20, from 1970	N/A
671822	Gasket for above	6.36	680196	Key blank, B20 (Neiman)	65
953259	Stud, in exhaust manifold	3.82	<u>For injection system. 1970-1973</u>		
190852	Nut	3.05	682110	Downpipe	133.13
663794	Bracket for downpipe, to ch. no. 16499	30.55	671822	Gasket for above	6.36
192040	Clamp for bracket above	9.67	953259	Stud, in exhaust manifold	3.82
940100	Bolt for ditto	0.76	190852	Nut	3.05
675825	Nut	0.76	682115	Front silencer	334.47
672029	Clamp for downpipe, from ch. no. 16500-	11.45	682118	Intermediate pipe, front	72.55
668510	Front silencer	314.36	682119	Middle silencer	215.09
667982	Intermediate pipe	82.73	682462	Clamp, at front of middle silencer	21.64
672330	Retainer, at rear of intermediate pipe	106.91	658653	Rubber cushion, in clamp	6.87
671800	Rear silencer	222.73	955529	Bolt for clamp	1.78
673224	Tailpipe	70 pc	955826	Nut	0.76
669316	Clamp for tailpipes (central)	8.65	682120	Intermediate pipe, rear	53.45
191466	Clamp for tailpipes (around pipe)	4.07	682117	Rear silencer	254.55
658201	Rubber cushion, in clamp	18.84	682463	Clamp, at front of rear silencer	16.55
273068	Fitting kit for complete system, -ch 16499	245.13	658653	Rubber cushion, in clamp	6.87
273185	Fitting kit for complete system, ch 16499-	175.13	669316	Rearmost clamp (central)	8.65
273069	Fitting kit for rear silencer & tailpipes	128.04	191466	Clamp for tailpipes (around pipes)	4.07
273185 (R)	Fitting kit for complete system (1800S) but without bracket 672330	48.36	658201	Rubber cushion, in clamp	18.84
CY2K	Complete boxed exhaust system, fitting kit, '61-66 (aluminised steel)	595.64	673224	Tailpipes, 1800E	70 pc
CY2K1	Complete boxed exhaust system, with fitting kit, '67-68 (aluminised steel)	626.18	684103	Tailpipes, 1800 ES	126.76 pc
			273317	Fitting ldt for complete exhaust system	104.11
			273318	Fitting kit for rear silencer (contains 682463, 669316, 658201 et. al)	49.13
			CY2K2	Complete boxed exhaust system, with	905.93

Starter motor (B18/B20)

		Price			Price
233679	Carbon brush set, starter 238620, early B 18	32.07	240604	Carbon brush set, starter 240360, B1 8/B20	33.35
233679(R)	Carbon brush set (repro)	21.38	240604 (R)	Carbon brush set (repro)	19.85

Dynamo Fitting (B18)

418354	(1.) Bracket (renew if bolt holes are oval)	31.82
403877	(2.) Rubber bushing	3.05
403894-R	(3.) Spacer sleeve in rubber bushing	9.16
955525	(4.) Bolt for fitting of bracket to engine block	0.76
FK-Dynamo 1	Fitting kit, dynamo/bracket (early, up to '66) contains upper/lower bolts, nuts, washers -5	4.58 kit
FK-Dynamo 2	Fitting kit, dynamo/bracket (late, from 117 on) contains upper/lower bolts, nuts, washers	4.58 kit
(CVI-AB18)	Bracket for fitting afterator in place of dynamo to B1 8 engine Lhd cars only	
238640	(6.) Charging relay (Bosch genuine)	198.55
1008	Decal (sticker) on side of relay (yellow)	5.09
190666	(7.) Screw (used up to approx. January 1964)	1.53 pc
FK-012	(8.) Fitting kit (used from approx Jan. '64 on)	2.04 kit

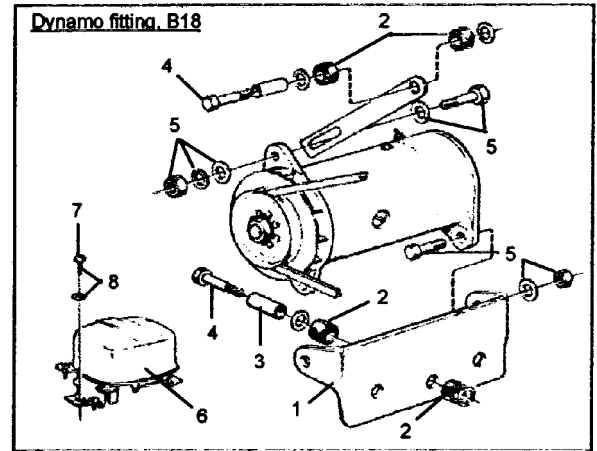

Dynamo Fitting (B18)

273500	(1) Carbon brush set, genuine	28.51
273500-R	Carbon brush set, repro.	16.55
238801	(2.) Return spring, carbon brushes	5.09 pc
11010	(3.) Front bearing	12.73
238793	(4.) Bracket (aluminium) for front bearing	118.36
190718	(5.) Nut	Call
955926	(6.) Lock washer	1.02
11009	(7.) Rear bearing (R)	14.00
238794	(8.) Housing for rear bearing	118.36
238804	(9.) Rotor (armature)	693.64
240561	(10.) Field winding, coil 1 (red)	Could be remade, if there is sufficient demand.
240562	(11.) Field winding, coil 2 (blue)	
#NAME?	Dynamo, exchange rebuilt Please call Alternator WI-11	

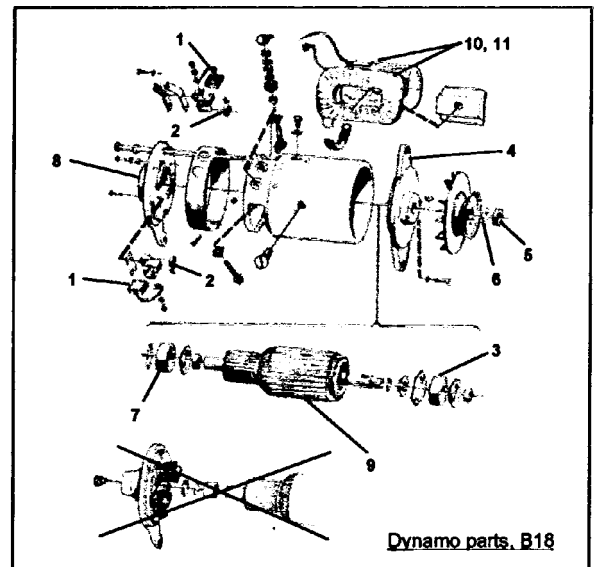

Alternator (B18B/B20)

Price		
419420 (R)	Alternator, 35A (w. built-in charge regulator)	403.45
419417 (L)	Bracket, convert dynamo to alternator (LHD)	82.73
5001612	(1.) Bosch alternator, exchange	Call
244456	(2.) Carbon brush kit, Bosch	14.00
1259303	(3.) Charging relay, SEV (replaces 419589)	107.93
1308030	(4.) Charging relay, Bosch (replaces 241534)	50.65
419417	(5.) Bracket (for RHD B20 cars only)	Call
955536	(6.) Bolt for bracket upper	1.27
955535	(7.) Bolt for bracket, lower	1.02
955565	(8.) Bolt, (afterator to bracket, LHD & RHD)	3.82
940280	(9.) Spring washer	1.02
955524	(10.) Bolt for tension adjuster	0.76
191172	(11.) Washer	0.51

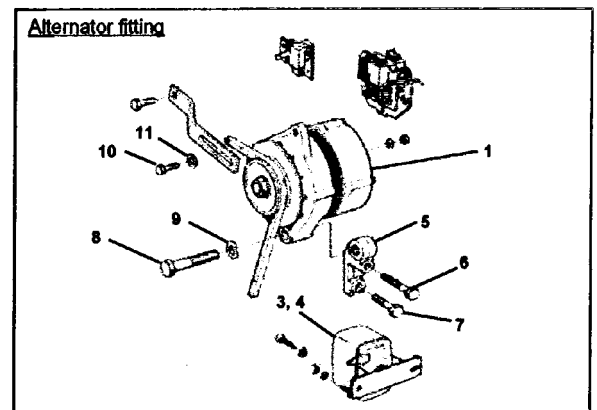

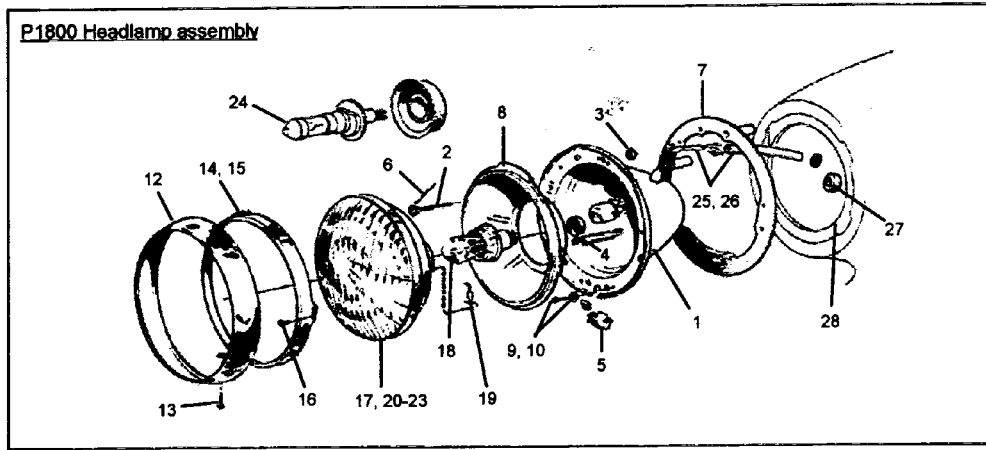

		Price			Price
1207412	(1.) Headlamp bowl, genuine (incls. nos. 2 & 3)	70.00	277730	(18.) Bulb for old-style assymetric lamps (12v)	6.36
668076	(2.) Adjuster screw	5.09	R12 (60/55W)	(18.) H4 bulb, fits old-styl hft. 241067/240518	12.22
668069	(3.) Plastic nut	5.09	240147	(19.) Spring clip	24.18
668078	(4.) Spring (for bowl)	8.91	1212963	(20.) Headlamp insert, H4 (gen. LHD) dat glass	77.64
668072	(5.) Retainer clip, for rim screw	10.18	1212963 (R)	(21.) HAamp insert H4, LHD (domed gl)	120.91
668077	(6.) Spring	1.27	1212962 (R1)	(22.) H/lamp insert, H4, RHD (flat glass)	123.45
665041	(7.) Gasket, behind headlamp bowl	28.00	1212962 (R2)	(23.) HAamp insert, H4, RHD (domed glass)	120.91
668075	(8.) Headlamp inner dish (bowl)	44.55	963187	(24.) Halogen H4 bulb, for current style hAamps	8.91
FK-01 3 (9, 10.)	Fitting kit, bowl to wing (&to ring 664285)	5 per lamp	668073-1	(25.) Headlampcable (P1800/S) (bullettype)	33.09
665040	(12.) Headlamp rim	91.64	668073-2	(26.) Headlampcable (1800E/ES) (spadetype)	36.91
191380	(13.) Headlamp rim screw	0.89	665330	(27.) Grommet for cable (R)	2.55
668079	(14.) Chrome headlamp retainer rim (genuine,')	47.09	6644864	Headlamp (LHD), 1961-1969 (compl.) R	330.91
668079-1	(15.) Chrome headlamp retainer rim (repro)	39.45	664486-2	Headlamp (LHD), 1970-197 (compl.) R	330.91
955118	(16.) Screw for retainer to inner dish (3 per hA)	2.04 pc	664285	(28.) Reinforcing ring (attached to ins. of wing)	61.09
241067 (RX)	(7.) Headlamp insert (Bosch assymetric, LHD)	129.82	664487	Foot dipper switch (use 668675)	61.09
240518 (RX)	(7.) Headlamp insert (Lucas assymmetric, RHD)	123.45	CVI-511	Relay, for headlamp dip via indicator switch	70.00

Indicator Lamps, Volvo P1800

Indicator - white lens - to ch. 6000 (& later on Swedish market)

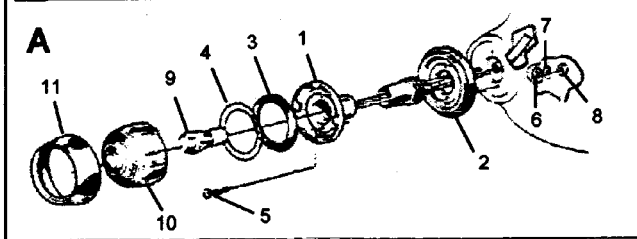

Indicator - twin-coloured lens - from ch. 6001-

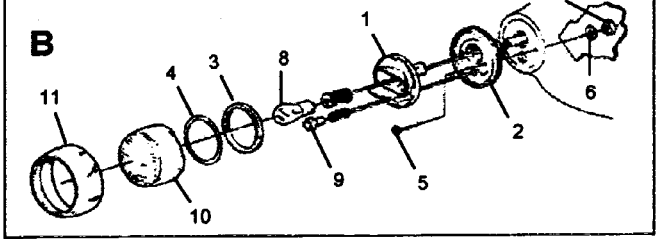

CM-1801	(1.) Bulbholder, early, all-white lens (1 bulb)	133.64	CM-1 802	(1.) Bulbholder, late, whitetyellow (2 bulbs)	133.64
664592	(2.) Rubber seal behind indicator	Modify 668200	668200	(2.) Rubber seal behind indicator	42.00
665043	(3.) Seal ring	4.07	665043	(3.) Seal ring	4.07
665044	(4.) Shp ring	2.04	665044	(4.) Slip ring	2.04
192010-S	(5.) Special fixing screw	6.36	192010-S	(5.) Special fixing screw	6.36
940090	(6.) Washer A	0.51	955918	(6.) Lock washer B	0.51
955918	(7.) Lock washer	0.51	955844	(7.) Nut	0.76
955844	(8.) Nut	0.76	277724	(8.) Bulb, indicator	2.04
277728	(9.) Bulb	Call	277705	(9.) Bulb, parking fight	2.55
e64590	(10.) Lens (all-white)	87.82	668196 (R)	(10.) Lens (amberhvite)	75.09
664589 (R)	(11.) Chrome rim	78.91	673509	(10.) Lens (all amber* (USAICAN)	61.09
			664589(R)	(11.) Chrome rim	78.91
U4576	Incdicator lamp, complete, all-whlte (R)	244.36			

REAR LIGHTS, P1800/1800S/1800E

6W96	(1.) Rear lens, all-red (USA to '69, others to '63)	100.55
668399	(2.) Rear lens, red/amber (1964-1972)	100.55
192020	(3.) Screw for lenses above (chromed)	2.55 pc
658833	Rubber sealing ring for screw	1.27 pc
682906	(4.) Taillamp lens, 1800E all-red USA. Possible to manufacture: let us know if interested.	Call
946227	(5.) Screw for 1 800E lens: also possible	Call
664498	(6.) Sponge gasket, under lens	25.20 pc
940090	Washer	0.51
955918	(7.) Spring washer	0.51
955844	(8.) Nut	0.76
665046	(9.) Gasket, lamp base to body	34.36
664505	(10.) Sponge seal behind lamp base (4/car)	10.18 each

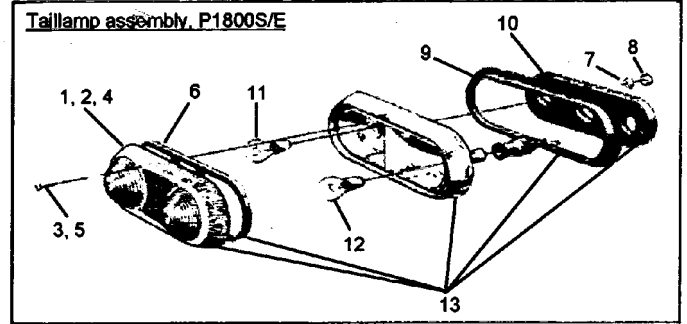

277728	(11.) Bulb, stop & parking light	3.05
277724	(12.) Bulb, indicators	2.04
664491	(13.) Stop & taillamp (with all-red lens 269), lhs	610.91
668400	(13.) Stop & taillamp (with 2-colour lens -72), lhs	610.91

NUMBER-PLATE LAMP (P1800S/E)

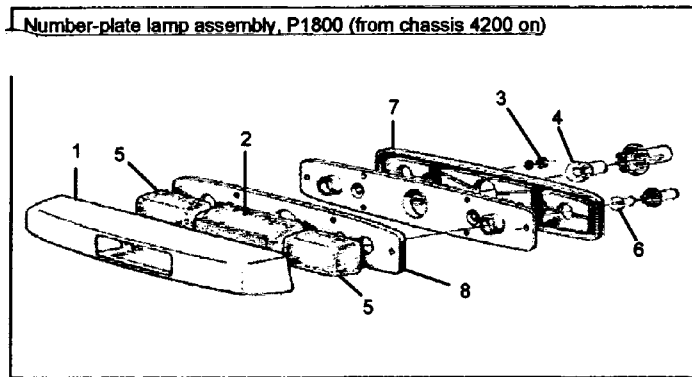

665450 (R)	Chrome housing, to ch 4199	316.91
668122 (R)	(1.) Chrome housing (from ch. 4200-)	311.82
9558"	(3.) Nut	0.76 pc
277724	(4.) Bulb, reversing lamp	2.04
277705	(6.) Bulb, no. plate lamp	2.55
668116	(7.) Rubber seal, lamp-to-body	42.76
668114	(8.) Sponge seal between lens & bulb holder	23.93
656086	Rear reflector (Swedish market only)	9.16

INTERIOR LIGHTS, VOLVO P1800

		<u>Price</u>
668418	(1.) Lens (later type)	38.18
277713	(2.) Bulb	2.55
5118	(3.) Base attachment screw	2.04
J4512-R	(4.) Door pillar switch (spring-loaded)	28 pc
95SU7	Nut	0.51

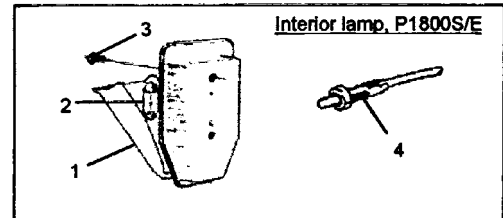

REAR LIGHTS, VOLVO P1800ES

686965M	Taillamp lens, all ES (lh/rh) (1,2.)	165.45 pc
956061	(3.) Screw (3 per lens)	0.51 pc
277721 (4, 5, 7)	Bulb, indicator/stop-light/reverse light	10 PC.
277707	(6.) Bulb, rear light	2.55

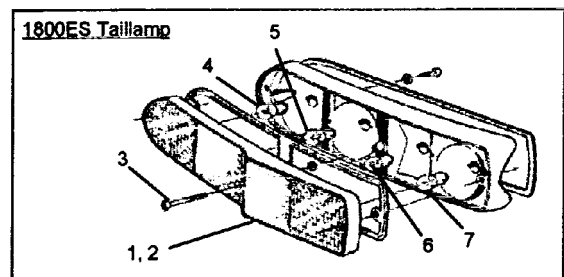

1214220	(8.) Number plate lamp, 1800 ES 1973	82.73 pc
277713	(9.) Bulb, number-plate lamp	2.55

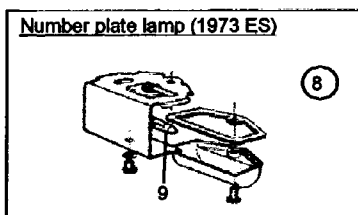

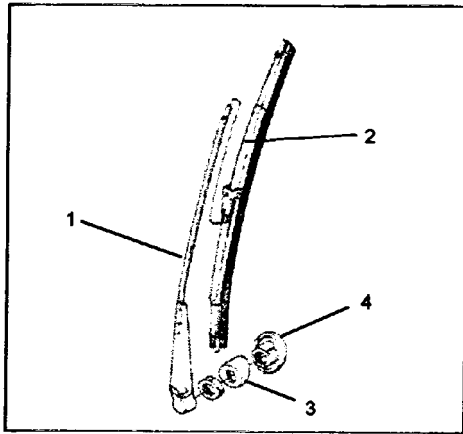

665636	(1.) Wiper arm, lh (61/71) (polished stainless)	44.55
665637	(1.) Wiper arm, rh (61-71) (polished stainless)	44.55
665638	(2.) Wiper blade, original Trico (61-71)	67.45 pc
665636/7/8-1 Wiper set: 2 arms + 2 blades C61 -711)		810 set
685696	Wiper arm (lh), 1971-1972	64.65
685697	Wiper arm (rh), 1971-1972	64.65
685709	Wiper blade, 1971-1972	42.76 pc
1213266	Wiper arm, lh & rh, 1973	63.89 pc
1213268	Wiper blade, 1973	NLA
664607	(3.) Chrome sleeve under wiper spindle	39.45 pc
669796	(4.) Rubber seal, under chrome	31.82 pc
660397	(4a.) Sponge seal, for wiper box	7.13 pc

Hubs for wiper arm attachment to spindle:

654460	(5.) Hub (with spines), for SWF/Autolfte (6 mm)	10.18
671911	(6.) Hub (with spines), for Electrolux (8 mm)	10.18
671541	(7.) Lock washer	5.09

Wiper mechanism, overhauled Call

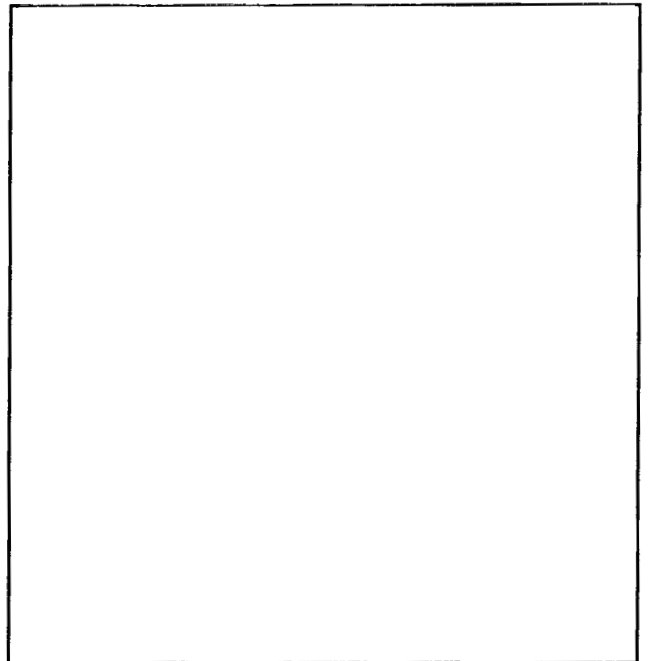
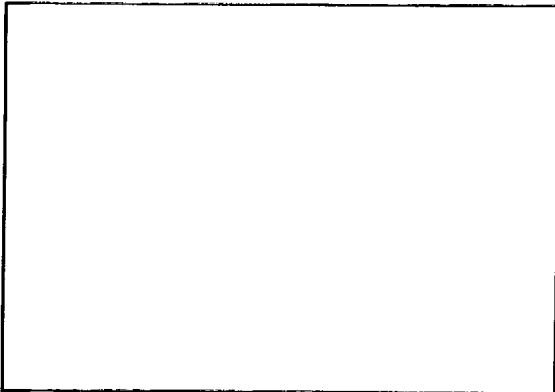

WINDSCREEN WASHERS, VOLVO P1800

		Price
668066	(1.) Washer jet (all models)	25.96 pc
'R61324	(2.) Washer motor (to chassis no. 23599)	126.00
j5636	(3.) Screw (3 per pump) (to ch. 7984)	0.76 pc
655512	(3.) Screw (3/pump, ch. 7985 - 23599)	0.51 pc
940155	(4) Lock washer	0.51
343188/378	Seals, for repair of old pump 661324	28 pair
666977	(5.) Washer bottle (genuine, w. lid, angle pipe)	53.45
659809	(6.) Clamp for genuine bottle	57.27
666977	(5) Wash bottle/clamp (larger diameter than orig)	72.55
663641	(7.) Angle pipe, from bottle top	3.05
192248	(8.) Clip	2.55 pc
661324-1	Washer set. 661324 + 666977	165.45
661324-2	Washer set. 661324 + 666977 (1,5)-l	171.82
102580	(9.) Plastic hose	Call
659248	(10) Three-way union	3.82
192581	(11.) Plastic hose	3.56 m
40136	(12.) Rubber grommet, early (l per car)	3.82
665038	(13.) Rubber grommet, later type (2 per car)	NLA
<u>from ch. no. 23600-</u>		
671723	(14.) Water bottle (later square type)	28.00
672408	(15.) Bracket for later bottle (to 1969)	15.27
683487	(16.) Bracket (LHD from 1970)	NLA
955137	(17.) Screw (for both brackets)	0.25 pc
688400	(18.) Washer pump (from ch. no. 23600-)	147.64

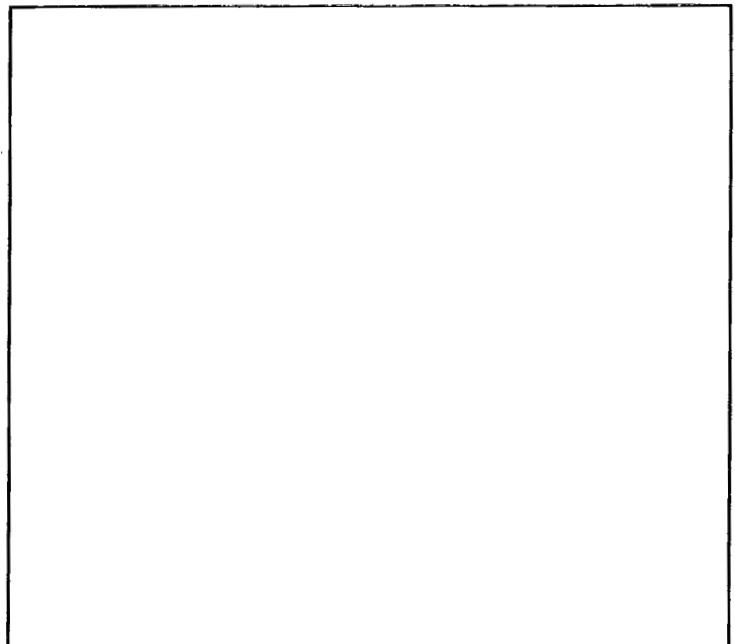

		Price
1377323	(1.) Friction plate (current Fichtel & Sachs clutch)	155.27
1220795	(2.) Pressure plate (F & S)	210.00
940135	(3.) Bolt	0.76 pc
380569	(4.) Release bearing for ditto (Volvo/Sachs gen.)	43.27
672122	(4.) Release bearing, Borg & Beck clutches (167-)	89.09
271263-S	Clutch kit, B18/B20, with bearing (F & 8)	286.36
11009	Support bearing, for gearbox input shaft (R)	14.00
1218634-S	Crankshaft seal kit (modern oil seal type)	100.55

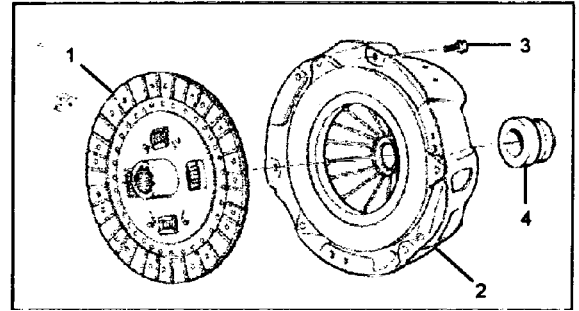

WINDSCREEN WASHERS, VOLVO P1800

653094(X)	(1.) Master cylinder (Lucas-Girling genuine)	183.27
656479	(2.) Filler cap (in original aluminium)	14.00
656480	(3.) Seal, under lid (included in rep. kit)	3.05
276513	(4.) Repair kit, master cylinder (genuine parts) (Includes red rubber assembly grease)	34.36
672917	(5.) Yoke, on pushrod	19.09
913128	(5a.) Clevis pin	6.36
907824	(6.) Split pin	0.25
135	(7.) Bolt	0.76
5949	(8.) Lock washer	0.51
,5847	(9.) Nut	0.51
669782	(10.) Slave cylinder (3/4") (-1964)	199.82
276451	(11.) Repair kit (genuine)	31.82
276451	(R) Repair kit (repro.)	19.09
673030	(10.) Slave cylinder (13/16") (1965268)	188.36
276572	(12.) Repair kit, 13/16" for cylinder 668365 (gen.)	Buy 273169
273169	(12.) Repair kit, 13/16" for cylinder 673030 (gen.)	53.45
273169 (R)	Repair kit (repro.)	21.64
955526	(13.) Bolt	2.04
955921	(14.) Spring washer	0.51
673034	(15.) Dust cover (fits all, but std. from '65-)	16.55
673035	(16.) Lock ring for dust cover	3.82
656455	(7.) Bleed nipple for slave cylinder	7.13
656456	Rubber cover on bleed nipple	1.53
673032	(18.) Pushrod (together with nos. 15. & 16.)	35.64
653433	(19.) Adjuster nut	6.87
955847	(20.) Lock nut	0.51
665254	(21.) Flexi hose	56.00
18651	(22.) Copper gasket	1.02
tOI 53	(23.) Nut	4.58
1206205	(24.) Clutch cable, B20 Lhd (genuine)	56.00
1206205R	(24.) Clutch cable, B20 Lhd	44.55
1206206	(24.) Clutch cable, B20 (rhd) (genuine)	92.91
1206208	(NB. Original part nos. were 1206207 (LHD) & (RHD). We could look into poss. supply if there is demand - fax or mail us)	
677431	(25.) Clutch fork (B20) (ref- 1212189)	187.09
677465	(26.) Rubber dust cover, B20	21.38
677531	(27.) Return spring, B20	17.31
663994	(28.) Dust cover, B1 8	35.64
653941	(29.) Return spring, B1 8	38.18
653238	(30.) Pedal rubber (B 18, B20 to ch -30000) (R)	11.45
666176	(30.) Pedalrubber (B20 from ch. 30001-) (R)	11.45
669950	(37.) Return spring, clutch master cylinder	10.69

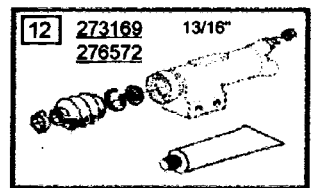
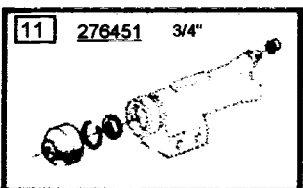
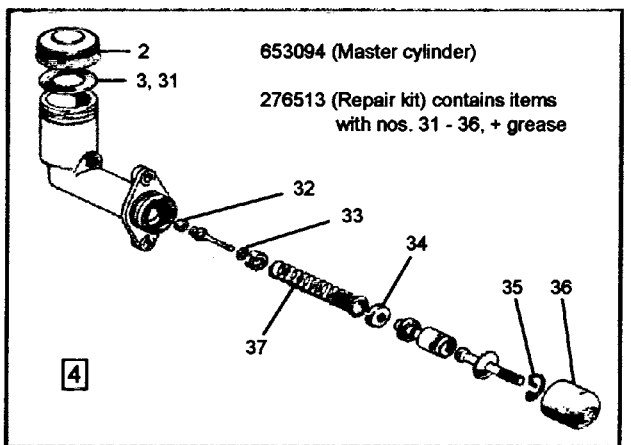
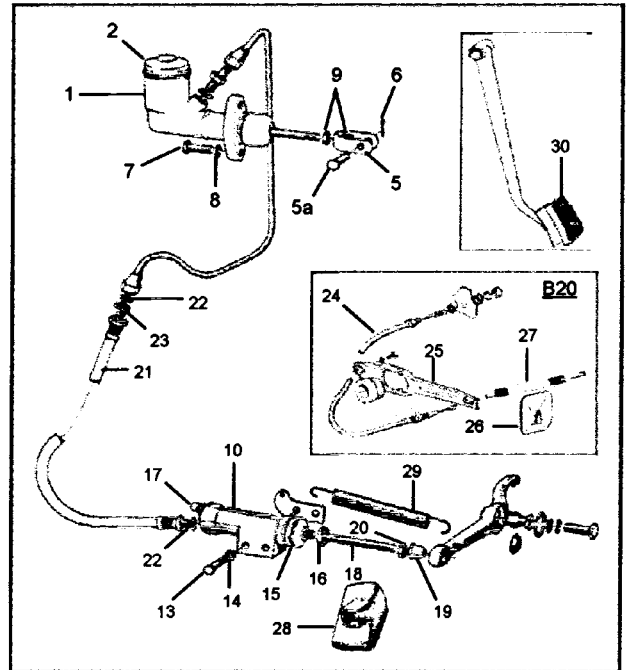

Package deal, complete overhaul

CVI-094031-1 Overhaul set, clutch hydraulics:

→ contains: 653094(X), 665254, 18651 and

Price

673030

351.27 kr

		Price			Price
662068	(1.) Gear knob, to ch. 30000	30.55	380800	(12.) Gasket (380128/380616)	7.13
680243	(2.) Gear knob, 1800E, ES	73.82	380446	(13.) Gasket, rear housing/spacer (M41)	6.36
657889	(3.) Gear lever gaiter, to ch. 30000	35.13			
681560	(4.) Gear lever gaiter, 1800E, ES	34.62	275416-R	Gasket set, M41	53.45
381107	(5.) Cork gasket, under Ild	8.91	656551	(14.) Thrust washer for laygear (21car)	11.20 pc
951695	Locking pin, middle selector fork	1.02	380157	(15.) Countershaft for laygear	184.55
67089	Ball, for locking gear in position, on selector	1.53	19567	(16.) Needle bearings for laygear (48 car)	0.71 pc
87972	Spdng, above ball	3.82	656138	(17.) Synchronising cone	70.00
11145	(6.) Beadng, oninputshaft	52.95	86713	(18.) Clamping ring for locating key	3.56
656505	(7.) Gasket	7.13	191498	(19.) Snap ring (thickness 2-1)	6.62
191685	(8.) Front oil seal	13.24	191499	(20.) Snap ring (thickness 2.2)	5.60
181120	(9.) Needle bearings for input shaft (14/box)	5.09 pc	656514	(21.) Locating key (3 per box)	6.36
			380141	(22.) Locating key (3 per box)	8.91
11013	(10.) Rear bearing M41 ('68)	26.98	191882	(23.) Key	15.27
11024	(11.) Rear bearing M41 ('69)	36.65	662292	(24.) Reverse fight switch, old inhibitor switch	67.45 pc

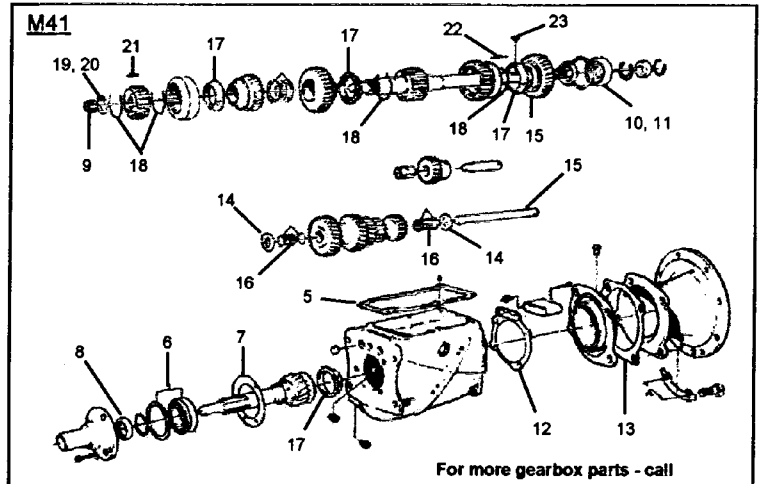
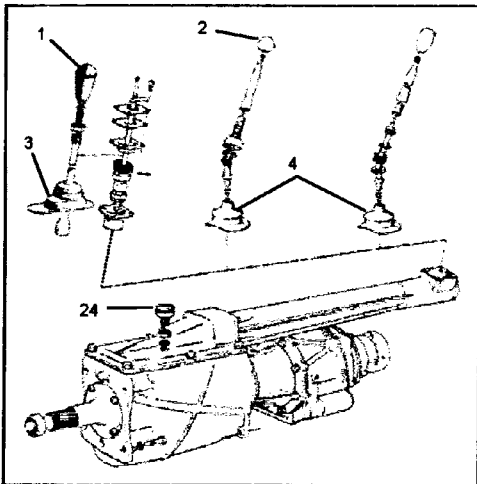

WINDSCREEN WASHERS, VOLVO P1800

B18B and B20E

672037	(1.) Universal joint greasable (up to 1966) (3/car)	26.73	B181B	(1.) Universal joint, B20E	70.76
192554	(2.) Grease nipple	2.55	231311	(1.) Universal joint, B20E (R)	22.91
118006	(3.) Circlip	2.55	24383	(3.) Circlip	2.55
1217606-1	Universal joint, non-greasable (1967-70) R	17.82	942803	(4.) Bolt	3.82
273202	(4.) Fitting kit for I flange	14 kit	950384	(4.) Nut	0.76
658653	(5.) Suspension bush, to 1966	6.87 pc			
181252	(6.) Support bearing (1961-1966)	57.27	686668	(8.) Rubber gaiter for bearing	71.53
658516	(7.) Bearing retainer (1961-1966)	124.98	686668-R	(8.) Rubber gaiter for bearing	38.18
675367	(8.) Rubber gaiter (genuine) (1967-1969)	36.91	183265	(9.) Support bearing (R)	47.09
A75367-1	(8.) Rubber gaiter (repro.) (1967-1969)85	1.02	683537	Support spring under rubber	4.07
696352	Rubber gaiter for bearing (B20F)	31.82	678824	(10.) Rubber seal	Call
0.81549	(9.) Support bearing (1967-1973)	24.18	955523	(11.) Bolt	0.76
675587	(10.) Rubber seal	28.00	955921	(12.) Spring washer	0.51
955523	(11.) Bolt	0.76	955894	(13.) Washer	0.51
955921	(12.) Spring washer	0.51	942402	(11.) Bolt (later type)	2.55
955894	(13.) Washer	0.51	231312	(14.) Yoke	740.73
656766	(14.) Yoke	184.55	231313	(15.) Companion flange, B20E	134.91

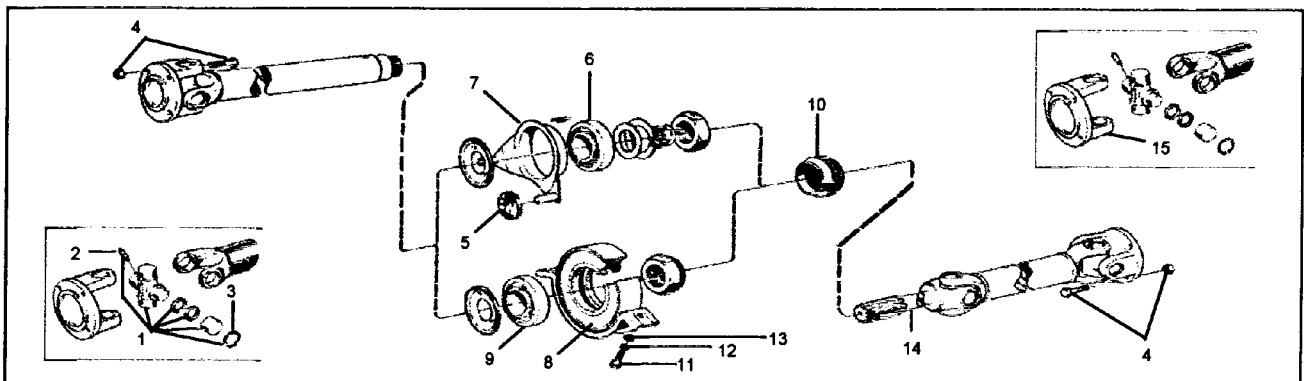

		Price		Price
380250	(1.) Main casing (early type only)	725.45	380411	(35.) Annulus (used only) Call
380251	(2.) Rear casing	470.91	380410	(36.) Annulus spigot bearing 33.09
380293	(3.) Pin stud (40mm) (6 per old)	7.64	380347	Relief valve (body/plunger/spring/plug/drig) 222.73
380294	Pin stud (30 mm) (7 per old)	7.64	380298	(38.) O-ring, on relief valve 6.11
380296	Pin stud (36mm) (2 per old)	10.69	380243	(39.) Oil pump piston, with roller and pin 206.18
380297	Pin stud (28mm) (11 per old)	14.00	380255	(40.) Spring, for oil pump 24.18
380294-1	Pin stud set (complete for 1 overdrive)	72.55 set	380270	(41.) Sleeve, for oil pump 95.45
955846	(4.) Nut (16 per old)	0.51	380262/380416	(42.) OP non-return valve (body, ball & spring) 355
955920	(5.) Spring washer (16 per old)	0.51	380243-1	Off pump (complete, nos. 39-42) 324.55
380258	(6.) Brake ring	216.36	380436	(43.) Plug, for oil pump 33.09
380183 (380434)	7 Spacer flange between O/D & gearbox	675	18820	(44.) Copper sealing washer 2.55
181063	(8.) Bearing, rear	67.45	380274	(45.) Oil filter, earlier type 53.45
380306	(9.) Bearing, middle	62.36	380440	(46.) Oil filter, later type 53.45
380307	(10.) Bearing, front	95.45	380280	(47.) Seal 9.67
380268	(11.) Carrier, for front bearing	94.44	380441	(48.) Plastic washer set, magnetic, for late filter 35.64
380271	(12.) Circlip	11.45	380282	(49.) Oil drain plug 28.00
380300	(13.) Circlip	11.45	18820	(50.) Copper sealing washer 2.55
380246(ER)	(14) Clutch cone, refined (exchange)	375.45	380617	(52.) Solenoid, 12v (B18) (genuine) 327.09
380277	(15.) Cork gasket, oil filter housing	15.27	380617-1	(53.) Solenoid, 12v (B18) (repro) 272.36
380351	(16.) Cork gasket, solenoid fitment	11.45	380249	(54.) Operating lever 67.45
380356	(17.) Gasket solenoid inspection cover	10.18	380415-1	Operating valve set: (55/56/57/ 58.) 113.53
380291	(18.) Rubber o-ring, on solenoid lever	4.58	380284	(59.) Plug, for operating valve 41.75
380186	(19.) Gasket, main casing to spacer flange	19.09	380290	(60.) Copper washer 6.62
380295	(20.) Oil seal	28.00	380275	(61.) Operating piston 31.82 pc
ID	Gasket set (with O-rings)	66.18	3=299	(52.) O-ring, on operating piston 7.13
4ID/3WM	Gasket set (With O-rings & oil seal)	86.55	380247	(63.) Spring set 39.45
CVI-WS-1	Wellseal sealing compound (for brake ring)	Call	380403	(64.) Central lubrication bush 70.76
380404	(21.) Planet carrier (complete)	(ref: 380245) 4250	380398	(65.) Cam (with woodruff key & lock ring) 99.27
380408	(22.) Planet gear set	call	380305-R	(66.) Speedo pinion, gear only (re-use shaft) 123.45
380410	(23.) Needle bearing, on planet gear	33.09	380192	(67.) Oil seal, at speedo, input 10.18
380409	(24.) Bearing pin (3/car)	44.55	191117	(68.) O-ring, on speedo pinion bush 2.55
380319	(25.) Thrust washer	6.62	OM92	(69.) Inhibitor switch, on gearbox lid (4th gear) 67.45
380320	(26.) Lock pin	2.04	11996	(70.) Copper seal 4.07
380409/10	Fitting kit for Planet gears (23/24,25/26)	250.73 kit	663605-R	(71.) Gearbox mounting, for M41 28.00
380244	(27.) Sunwheel	113.27	11009	(72.) Support bearing for gearbox input shaft (R) 14.00
380413	(28.) Uni-directional clutch retainer	31.82		
380414	(29.) UDC circlip	53.45		
380259	(30.) UDC bearing cage (cone)	120.91		
273152	(31.) UDC roller set	UDC (compl.) 975		
380257	(32.) UDC clamping ring			
380272	(33.) UDC inner bearing cone	(Now 274043D)		
380256	(34.) Thrust washer	33.09		

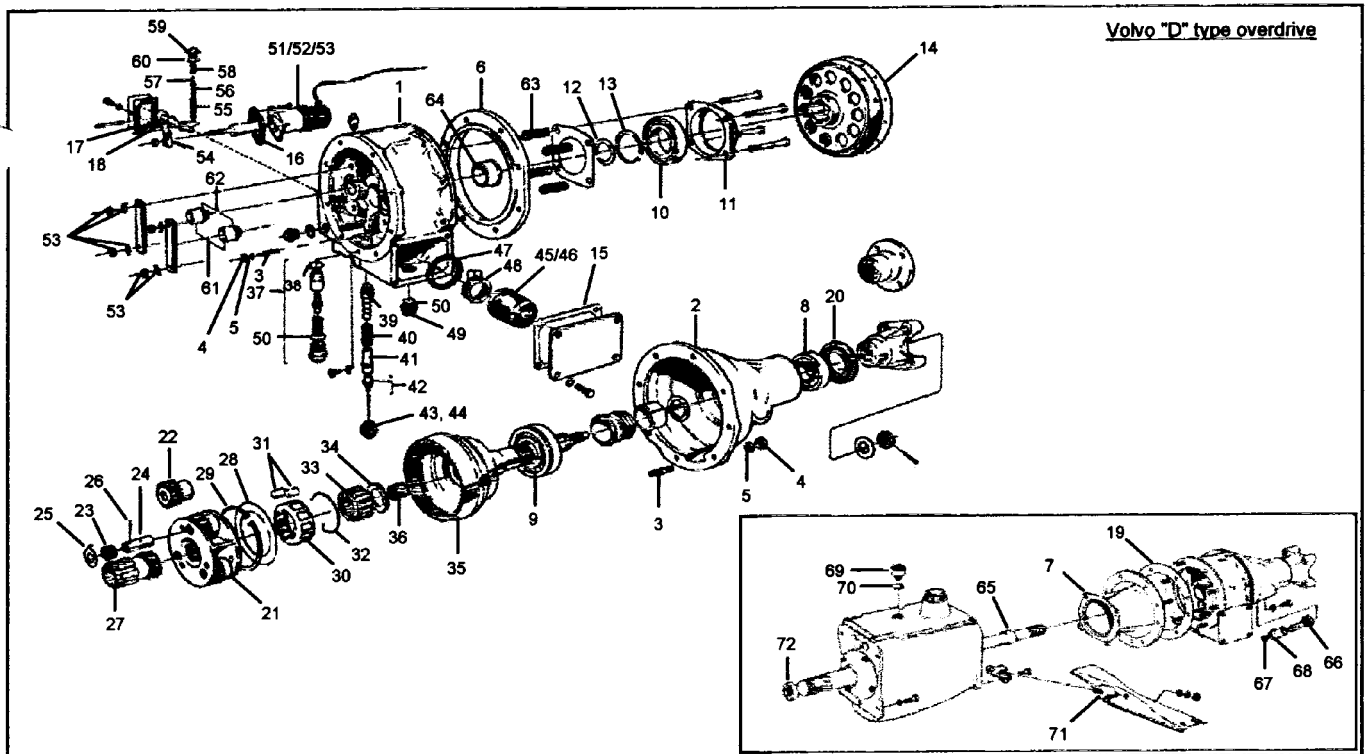

254561	Overdrive unit, marked 115602, '68-'70	1896.36	273135	(29.) Seat with seal, relief valve	See 380778-1
254601	Overdrive unit, marked 115614, '71-'73	1896.36	380747	(30/31.) Sleeve, for relief valve	See 380778-1
273133	(1.) Main (front) casing	369.09	380768	(31.) O-ring	6.62
380673	(2.) Rear casing	318.18	380779	(32.-38.) Piston assembly	See 380778-1
380675	(3.) Brake ring	235.45	936-22	c *(37.) Spring (small)	12.73
380771	(4.) Solenoid (incl. O-rings)	295.02	380778	(39.-45.) Piston, under 380779	See 380778-1
380689	(5.) Clutch cone (black lining) (now-350276)	394.55	380770	(47.) O-ring	6.62
380689 (ER)	(5.) Clutch cone (grey lining) (Exchange!)	Call	380778-1	Relief valve (nos. 29-45 on diagram)	282.55
11013	(6.) Bearing, rear	26.98	271454	Relief valve (current modified type, w plug)	324.55
181092	(7.) Bearing, middle	78.91	380729	(48.) Oil filter	47.09
380693	(8.) Bearing, front	162.91	380719	(49.) Oil strainer	49.64
380694	(8a.) Bearing carrier	123.20	380672	(50.) Pressure plug	14.00
380720	(9.) Gasket, oil sump (ref: 3502464)	16.55	18665	(51.) Copper washer	2.04
380772	(10.) O-rings, on solenoid	6.11 pair	380721 (52/53/54.)	Oil pump piston (with slide and pin)	725
380618	(11.) Gasket between O/D and gearbox	8.40	380725	Sleeve, for oil pump	123.45
380674	(12.) Gasket, in front of brake ring (ref. 3502462)	19.09	190611	(55.) Ball (loose 21 kr,)	} 255 set
380676	(13.) Gasket, behind brake ring (ref. 3502463)	19.09	380766	(56.) O-ring (loose : 26 kr 273134-1 =	
380684	(14.) Oil seal (ref: 1232013)	28.00	273134	(57/58.) Seat + spring, non-ret. valve	
M41J	Gasket set (with O-rings)	73.82	380726	(59.) Plug, Incl. O-ring	42.00
M41J/380684	Gasket set (With O-rings and oil seal)	89.09	380767	(60.) O-ring	6.62

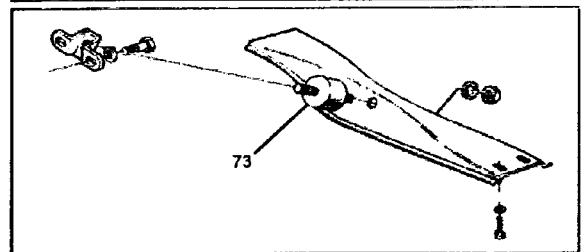
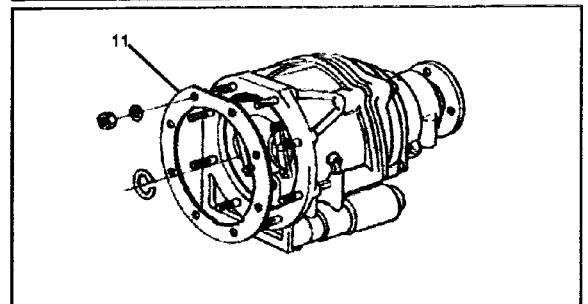
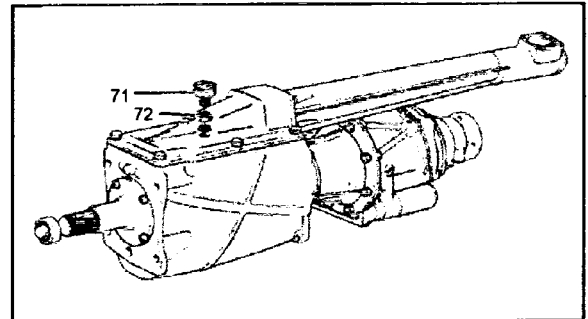
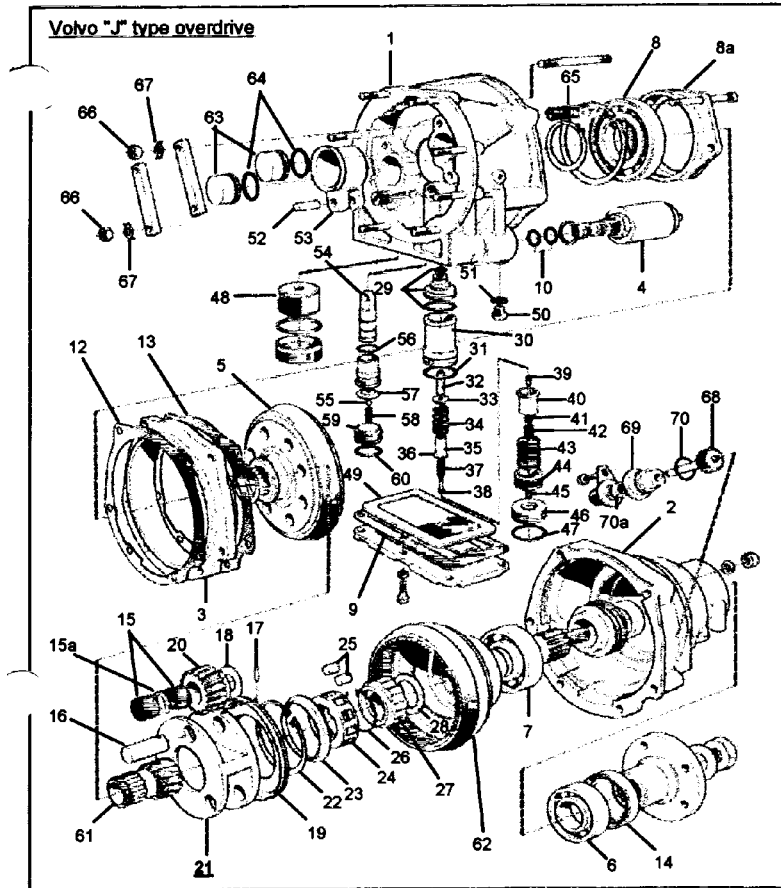

380707	(15.) Needle bearing for planetary gear	See Kit	380699	(61.) Sunwheel	171.82
380709	(16.) Bearing pin (3/car)	See Kit	380679	(62.) Annulus	Call
380763	(17.) Lock pin (3/car)	See Kit	681"54	(63.) Operating piston, Mid. O-ring (380698)	70.00
360707-1	Fitting kit, compl. planet gr. assembly (incls. nos. 15,15a, 16,17, 18)	250.73	6814455	(64.) O-ring 380756	6.36
380704	(19.) Oil catcher, behind planet gear carrier	33.09	273151	(65.) Spring set	47.09
380706	(20.) Planet gear	Call	380887R (66/67.)	Lock nut (replaces 955846 & 380303)	6 pc.
360705	(21.) Planetary carrier (complete) (27%)	649.09	380753	(68.) Speedo drive gear	111.75
380714	(22.) UDC (uni-directional clutch) retaining circlip	19.09	380751	(69.) Bearing pinion (now 1232153 + 948602)	173.09
380713	(23.) UDC oil slinger	34.36	380757	(70.) O-ring	7.38
380712	(24.) UDC bearing cage (retainer) (complete)		380752	(70a.) Oil seal	11.45
273152	(25.) UDC roller set (complete)	69756.40	662292	(71.) Inhibitor switch, on gearbox lid	67.45
380257	(26.) Clamping ring (complete)	248.18 kr	11996	(72.) Copper seal	4.07
380711	(27.) UDC inner bearing cone (complete)		663605-R	(73.) Gearbox mounting, for M41	28.00
380715	(28.) Thrust washer	13.49			

Wheel bearings, oil seals, brake drums (P1800/S)

89679	(HD) (7.) Drive shaft (NBI Reinforced!)	623.64 pc	673797	(21.) Brake drum, genuine Mith hub)	327.09
181217/181189	(Rear wheel bearing)	90.36	673797-1	Brake drum (without hub)	162.91
192550	(9.) Oil seal	14.76	654490	(22.)Wheel bolt	11.45
673788	(10.) Gasket (2 per wheel)	6.36 pc	87699	Wheel nut	2.55
673791	(11.) Oil seal, outer (includes felt ring 19246)	24.18	9991791 (R)	Hub puller, for brake drum	140.00
19246	(12.) Felt ring	7.13			
CVI-605	Wheel bearing kit (nos. 8- 11)	133.64			
160553	(13.) Woodruff key	17.56			
153031	(15.) Castellated nut	22.91			
191174	(16.) Split pin	0.51			
955676	(17.) Bolt	2.04			
955848	(18.) Nut	0.76			
940097	(19.) Washer	0.51			
955950	(20.) Lock washer	0.51			
FK-009	Fitting kit for 1 brake backplate (17-20.)	10.18			

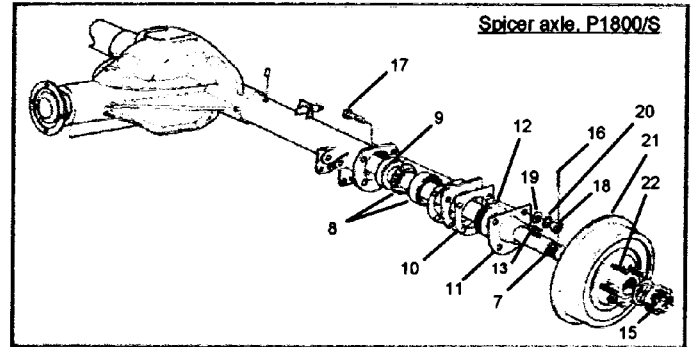

Wheel Bearings, Oil Seals (1800E/ES)

383-168	(1.) Spacer ring (R)	23.42			
384728	(2.) Wheel bearing	75.09			
384710	(3.) Oil seal (R)	16.55			
CVI-570	Wheel bearing kit (1 wheel) (includes items above)	100.55			
955569	(4.) Bolt, for support stay	4.58			
950356	(5.) Nut	2.04			
941858	(6.) Bolt, for torque rod	12.22			
950377	(7.) Nut	12.22			
940115	(8.) Bolt	0.76	676338	(10.) Wheel bolt (now 1229808)	16.29
942336	(9.) Lock washer	0.51	688984	Wheel nut (chromed), E/ES	8.91
			688984-20	Wheel nut set (20 pcs.)	142.55

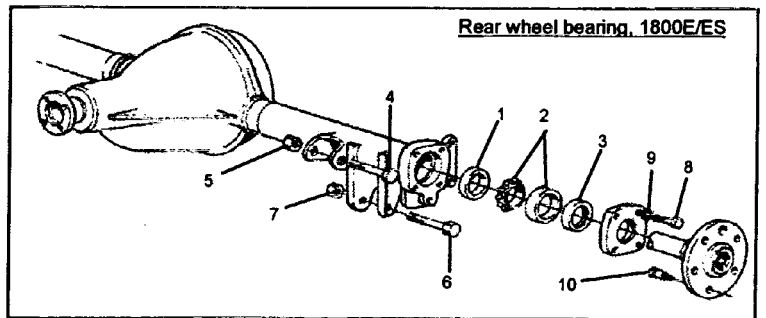

Pinion & Differential carrier bearings, M27/M30 (Spicer): Pinion Oil seal (all)

181301	(23.) Inner cone, pinion (front)	58.04			
181302	(24.) Outer cup, pinion (front)	19.85			
181303	(25.) Inner cone, pinion (rear)	56.00			
181304	(26.) Outer cup, pinion (rear)	34.11			
181305	(27.) Inner cone, differential (2/car)	45.31			
181306	(28.) Outer cup, differential (2/car) (M27 axle)	71.78			
181662	(28.) Outer cup (M30 axle)	36.91			
80507	(29.) Pinion oil seal, Spicer (early leather type)	53.45			
942905	(30.) Pinion oil seal, Spicer (replaced 80507)	31.82			
9143317	(30.) Pinion oil seal, Spicer (current genuine)	44.55			
	Note that all seals above come from the genuin Volvo suppliers: quality is first class.				
RH - SPICER	Repair sleeve, for sealing surface on pinion	285			
80506	(31.) Oil deflector, behind oil seal	7.13			
88726	(32.) Nut for companion flange	30.04	942402	(35.) Bolt for rear cover, late type (10 per car)	2.55
80513	(33.) Washer	Call	955949	(36.) Spring washer	0.51
89254	(34.) Gasket for rear cover	11.45	952359	(37.) Oil filler plug	15.78
955523	(35.) Bolt for rear cover (10 per car)	0.76			

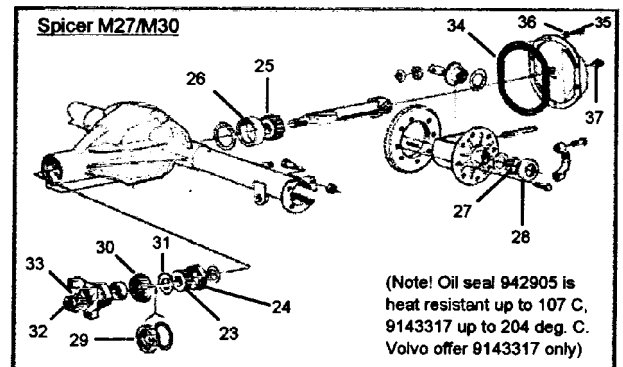

		Price
653442	(1.) Suspension arm, lhs (with nuts/washer)	87.82
653443	(2.) Suspension arm, rhs (with nuts/washer)	87.82
653448	(3.) Washer	6.36
653461-R	(4.) Front rubber bush (2 per arm)	5.09
653461-HR	(4.) Front rubber bush (stiffer rubber)	6.36
653456	(5.) Clamp	Call
950394	(6.) Nut for clamp	0.76
663972	(7.) Rubber ring around axle	28.00
667581	(8.) Torque rod (from approx. March '63)	150.69
653168-R	(9.) Rear rubber bush (2 per rod)	6.36
653168-HR	(9.) Rear rubber bush (stiffer rubber)	7.64
667535	(10.) Washer	8.91
950366	(11.) Lock nut (special low nut)	2.04
662797	(12.) Front silerdbloc bush for torque rod	21.64
955568	(13.) Bolt for silentbloc	4.58
950366	(14.) Nut (special low nut)	2.04
276553	(15.) Shock absorber kit (2 per car)	100.55 pc
BIL AR	Bilstein gas shock, rear	222.73
670129	(16.) Rubber cushion, for shock abs. location	3.05 pc
667843	(17.) Rear spring (genuine)	174.36
667154	(18.) Spring seat, lower	70.76
667686	(19.) Rubber cushion, under spring seat	51.93
668777	(20.) Spring seat, upper	Call
659325	(21.) Rubber spacer	28.00
83108	(22.) Rubber buffer, above spring	31.82
955783	(23.) Nut	Call
955922	(24.) Spring washer	0.51

		Price
672251 --	(25.) Check strap	14.00
89818	(26.) Shaped washer	8.91
940115	(27.) Bolt	0.76
940108	(28.) Spring washer	1.02
83107	(29.) Rubber cushion (D = 37)	22.91
663989	(29.) Rubber cushion (D = 45)	NLA
87033	(30.) Rubber bush, for Panhard rod	5.60
955565	(31.) Bolt	3.82
950366	(32.) Nut (special low nut)	2.04
120802	(33.) Washer	5.09

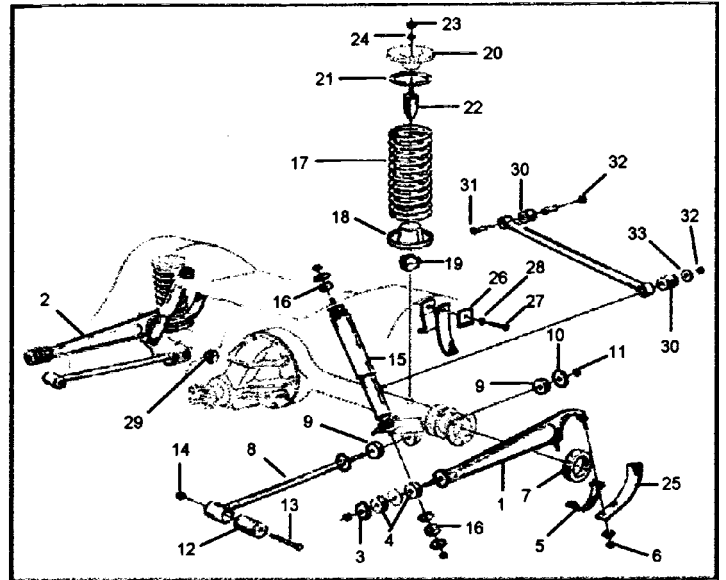

REAR AXLE SUSPENSION, 1966-1973

672610	(25.) Suspension arm (with bushes - genuine)	Call
672610-R	(25.) Suspension arm (with bushes)	235.45
672609/10	(R) Suspension arm, supplied without bushes	176.91
662797	(26.) Bush, front (for above suspension arms)	21.64
955569	(27.) Bolt	4.58
950356	(28.) Nut	2.04
675771	(29.) Bushing (ch. 165W - 25668)	108.18
678887(R)	(30.) Bushing (ch. 25669)	140
941858	(31.) Bolt for rear bushes	12.22
377	(32.) Nut	
672616	(33.) Torque rod	148.91
672226	(34.) Bush, front & rear (ch. 16500 - 25668)	21.64
678790(R)	(35.) Bush, front & rear (ch. 25669-)	85
955569	(36.) Bolt for above (front and rear)	4.58
950356	(37.) Nut	2.04

Shock Absorbers and Fittings See above

657843	(40.) Rear spring	174.36
659154	(41.) Spring seat lower	70.76
667686	(42.) Rubber cushion, under seat	51.93
668777	(43.) Spring seat, upper	Call
659325	(44.) Rubber spacer	28.00
83108	(45.) Rubber buffer, above spring	31.82
83107	(46.) Rubber cushion (D = 37)	22.91
663989	(46.) Rubber buffer for axle (D = 45)	NLA

Panhard rod and check strap See above

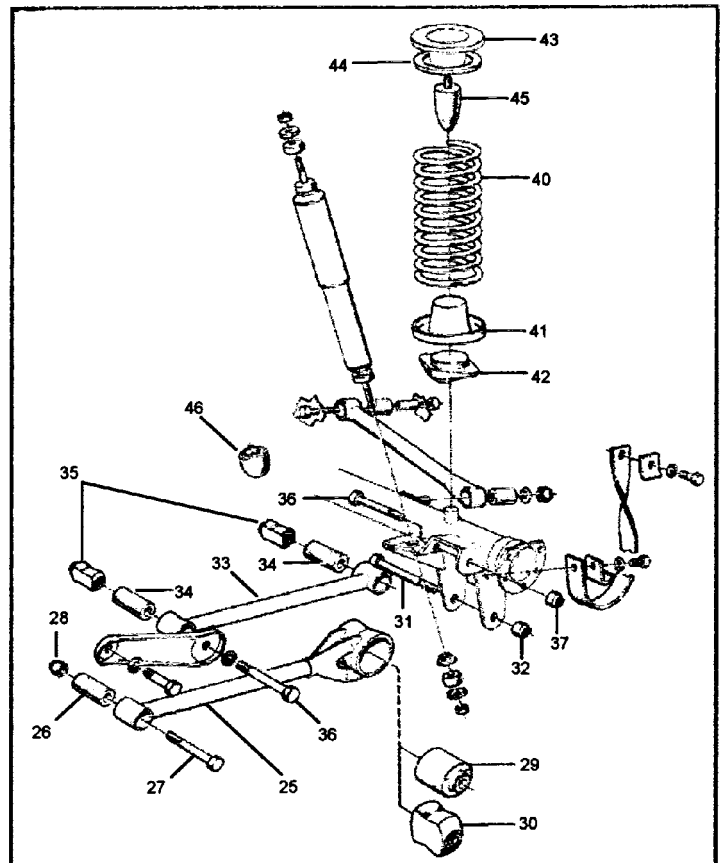

		Price			Price
671351	(1.) Lower wishbone (h)	318.18	660088	Lower anchorage, early type	Call
671352	(2.) Lower wishbone (rh)	318.18	672228	(28.) Lower anchorage, late type	23.93
671440	(3.) Upper wishbone (from August 1965)	302.91	955523	(29.) Bolt	0.76
			955949	(30.) Lock washer 2	
87033	Lower inner wishbone bush, ch. -7999	5.60	1210298	(31.) Lower ball-joint (genuine)	112
653410	Sleeve	28.00	190142	(32.) Castle nut	22.65
653409	U bolt	28.00	907849	(33.) Split pin	0.25
120802	Washer	5.09			
950366	Lock nut, outer	2.04			
663675	(4.) Lower inner wishbone bush, ch. 8000-	21.64	273038	(35.) Lower ball-joint kit (genuine)	173.09/side
192113	(5.) Bolt for bush (long)	67.45	273038-1	(35.) Lower ball-joint kit (Italian)	91.63/side
950357	(6.) Nut	3.56			
87033	(7.) Upper inner wishbone bush (all)	5.60	273004	(36.) Upper ball-joint kit, to July 1965	78.90/side
653410	(8.) Sleeve	28.00	273030	(37.) Upper ball-joint kit (current gen. - Italian)	53.45/side
653409	(9.) U bolt	28.00			
120802	(10.) Washer	5.09			
950366	(11.) Lock nut	2.04			
83107	(12.) Rubber cushion, upper wishbone	22.91			
6M03	(13.) Rubber bump stop	42.76	666525	(38.) Brake disc -ch 30000 (gen, w. hub & bolts)	406
653330	(14.) Bracket (repi. 663477)	39.45	666525-1	(39.) Brake disc (without hub)	162.90
1210389	(14.) Bracket (Late E/ES)	92.15	667238	(40.) Hub for brake disc (genuine)	Call
83125	(15.) Anti-roll bar bush (8 per car)	3.05	657874	(41.) Wheel bolt	11.45
191707	(16.) Bolt for anti-roll bar	26.73	87699	(42.) Wheel nut	2.50 PC.
17841	(17.) Spacer tube (must shorten)	6.36	682304	(38.) Brake disc, from ch 30001 -	See Brake system
55526	(18.) Washer	1.27			
955826	(19.) Nut	0.76	88640	(43.) Inner grease seal (R)	15.27
273239-1	And-roll bar kit for one side	45.82	907849	(44.) Split pin	0.25
657839	(20.) Anti-roll bar bush, front (2 per car)	6.36	273160-1	(45.) Wheel bearing kit (includes 88640) (R)	95.45/side
672217	(21.) Clamp	Coming soon	1161241	Tube of grease (80 g)	10.69
940114	(22.) Bolt	0.51	87464	(46.) Thrust washer	11.45
955950	(23.) Lock washer	0.51	153042	(47.) Nut	8.91
65318.4	(24.) Spring (genuine)	108.18	87465	(48.) Grease cap	15.27
653642	(25.) Rubber seal, on spacer washer	29.27			
276552	(26.) Shock absorber ldt, front (2 per car)	100.55	654107/06	(49.) Adjuster shim, thickness 0, 15/0,50	2.55 pc
BIL AF	Bilstein front gas shock absorber	222.73	654105	(49.) Adjuster shim, thickness 1,00	2.55
670129	(27.) Rubber cushion, shock absorber fitting	3.05	658769f7O	(49.) Adjuster shim, thickness 3,00/6,00	3.82 pc

(NB. These are current genuine - Italian-made: new German- made coming soon - register interest! 273004 has spacer washer, and no grease nipple, but old-style genuine with grease nipple

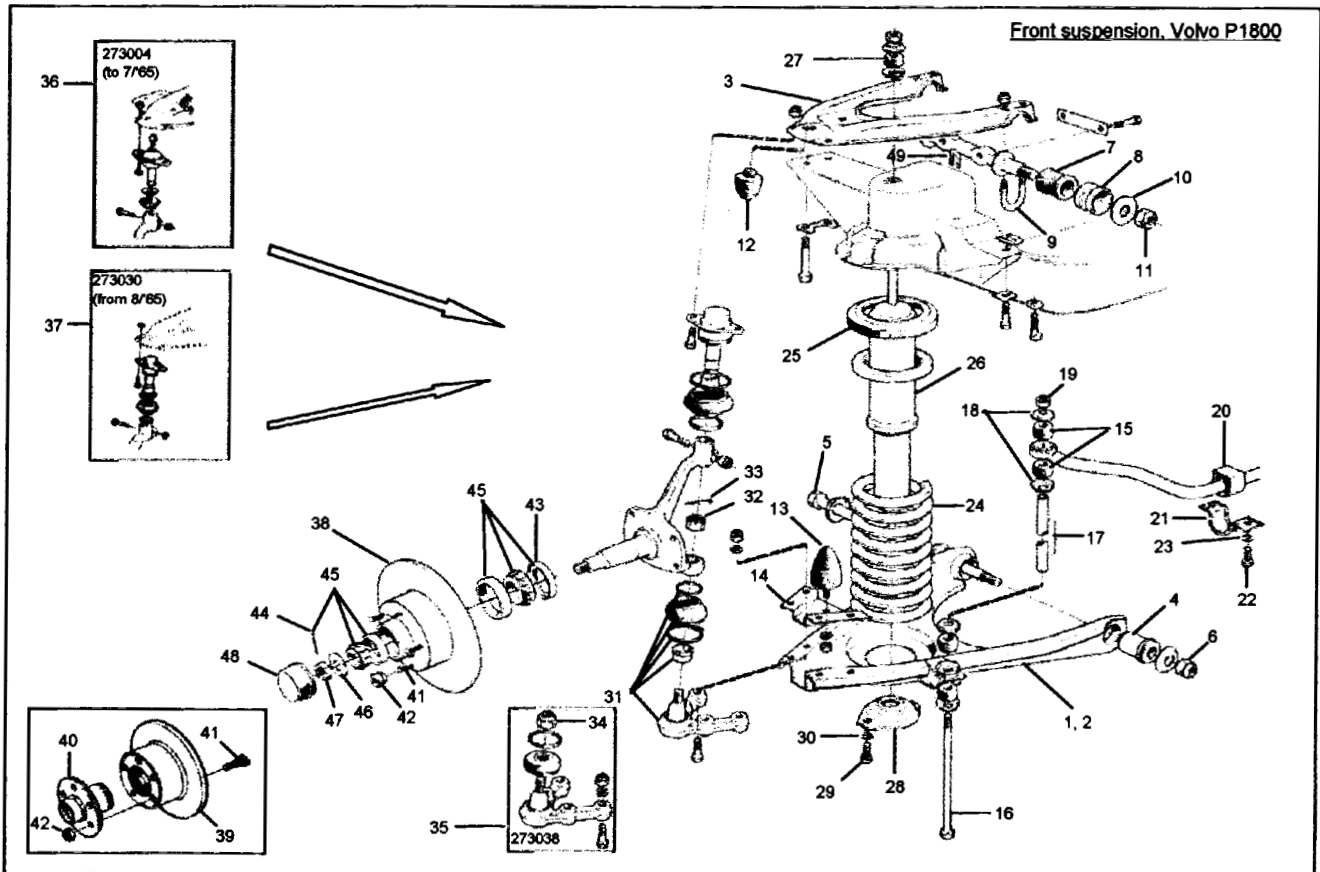

		Price
250085	OERXI.) Steering-box (LHD), 1961-1969	954.55
250086	OERXI.) Steering-box (RHD), 1961-1969	954.55
250143	OERXI.) Steering-box (LHD), 1970-1973	954.55
250144	OERXI.) Steering-box (RHD), 1970-1973	954.55
	(NB. Steering-boxes are overhauled, and sold on exchange	
654011	(2.) Sealing collar, on steering column	6.11
664428	(3.) Coupling	82.73
114271*	(4.) Oil seal, lower	14.00
678249*	(5.) Oil seal, upper (genuine)	16.55
659214	(6.) Lid (1961-1969)	114.55
180764	(7.) Oil filler plug (1961-1969)	35.38
678240	(G.) Lid (1970-1973)	114.55
678241	(7.) Oil filler plug (1970-1973)	6.36
656704*	(8.) Gasket under lid	3.82
&5627*	(9.) Bush for Pitman arm shaft (2 per box)	12.73 pc
85618	(10.) Bearing	57.27 pc
85616	(11.) Bearing cup, upper	245.64
&5617	(12.) Bearing cup, lower	91.13
656707*	(113.) Adjuster shim, 0.10 thickness	5.60 pc
656708*	(13.) Adjuster shim, 0.12 thickness	6.36 pc
656709/10	(13.) Adjuster shim, 0.1510.30 thickness	5.60 pc
190296*	(14.) Lock washer, with bendable tab (genuine)	2.55 pc
54929	Steering-box re-bushing set	72.55
56929 (R)	Steering-box set (less shims 1 tab washers)	53.45
662349	(15.) Pitman arm shaft (LHD)	Call
662350	(15.) Pitman arm shaft (RHD)	700.00
662347	(16.) Steering worm, LHD (up to 1969)	Call
662348	(16.) Steering worm, RHD (up to 1969)	Call
682630	(16.) Steering worm (1970-1973)	Call
W4477	(17.) Horn button	NLA
665108	(18.) Housing for indicator arm	89.09
85611	(19.) Bearing	119.64
85612	(20.) Spring	12.22
85613	(21.) Seat	11.45

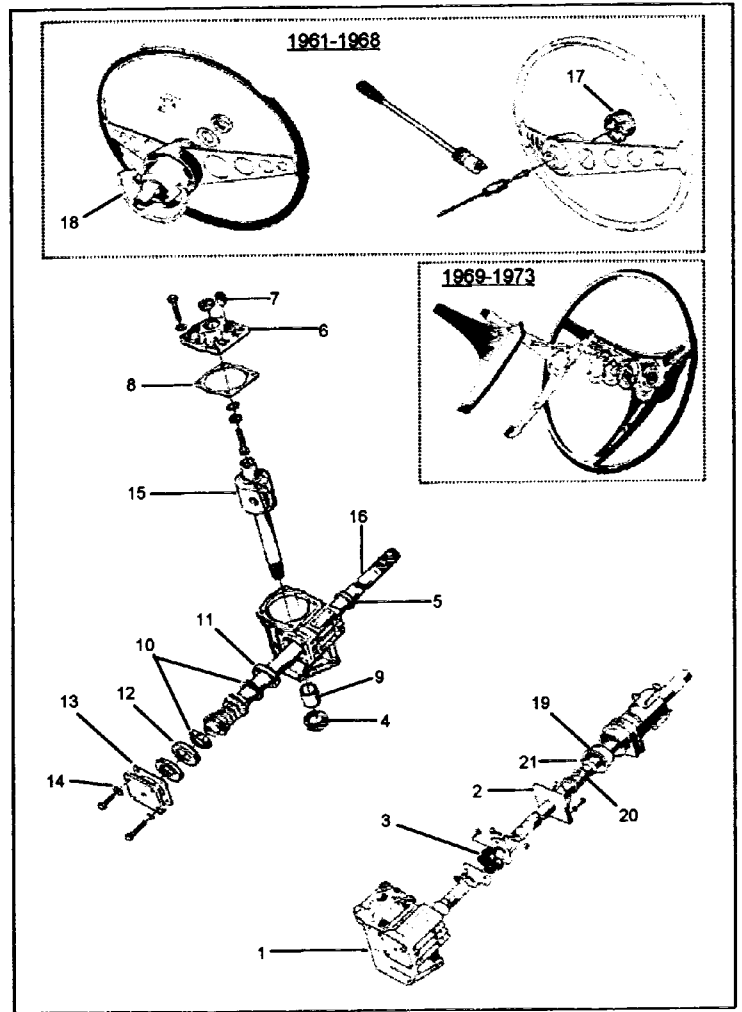

STEERING TRACK RODS AND TIE-RODS

f3bub9tJ	(11.) Track rod, lhs (genuine)	114.55
658597	(2.) Track rod, rhs (genuine)	114.55
658596-1	Track rod (lhs) (Italian)	82.73
658597-1	Track rod (rhs) (Italian)	82.73
q584311	(3.) Tie-rod end, lhs (genuine)	75.09
i8432	(4.) Tie-rod end, rhs (genuine)	75.09
658431-1	Tie-rod end (lhs) (Italian)	49.64
659432-1	Tie-rod end (rhs) (Italian)	49.64
660979	(5.) Tie-rod (complete with tie-rod ends)	NLA
190573	(6.) Castellated nut	24.18
907824(S)	(7.) Split pin (stainless)	0.51
670877(OR)	(8.) Rubber dust cover	15.27
670420/672785 (R)	Lock ringhensioner ring (9/10.)	

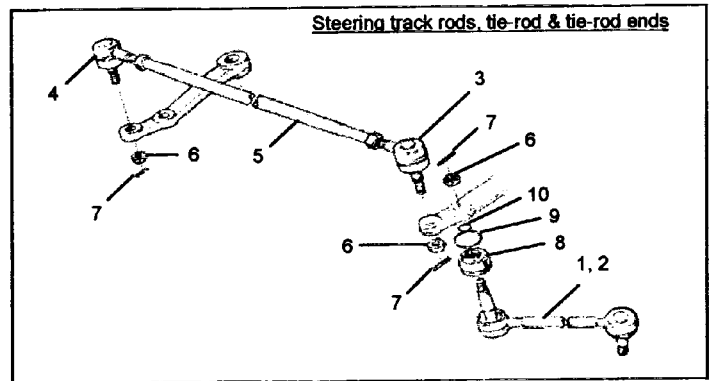

IDLER ARM

54928	Repair kit for early idler arm (to late 1961)	Call
663709	(11.) Bush for idler arm (62-66)	28 pc
666402	(2.) Shaft	138.47
669255	(3.) Vulcollan washer	2.80 pc
950356	(4.) Nut	2.04
914170	(5.) Grease nipple	2.55
276521	(6.) Repair kit for idler ann (1962-1966)	2.55
671444	(7.) Bush for idler arm, 1967-70	42.76
671444-1	(7.) Bush (non-gen.)	28.00

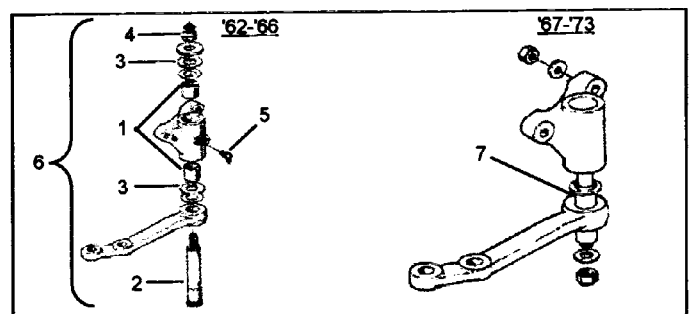

Brake master cylinder

		<u>Price</u>
655879	Brake master cylinder, up to chassis no. 35	473.45
276405	Repair kit (genuine)	40.73
662186	(1.) Brake master cylinder, B1 8	220.18
666144	(2.) Filler cap	17.31
276461	Repair kit, genuine	70.00
276461 (X)	Repair kit, genuine Qnclud piston ass*.)	86.55
276461-1	Repair kit (non-gen., rubbers + valve only)	30.55
672425-R	Brake light switch	15.27
672917	(3.) Yoke	19.09
907824	(4.) Split pin	0.25
940135	(5.) Bolt	0.76
955949	(6.) Lock washer	0.51

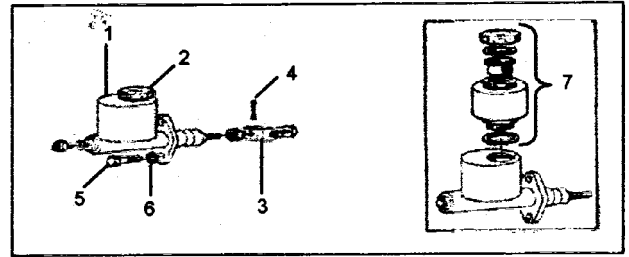

672769-R (7.) Secondary (accessory) reservoir, complete 340

Handbrake system, to 1969

682922	(11.) Handbrake cable, genuine (2 per car)	47.09 pc
80969	(2.) Clamp (U-boft), cable to body	4.33
950373	(3.) Lock nut	1.27
658843	(4.) Clamp, cable to backplate, lh	21.64
658844	(5.) Clamp, cable to backplate, rh	21.64
191260	(6.) Screw	NLA
660651	(7.) Plastic brace on handbrake lever	9.67
666418	(8.) Draw brace	10.18
1-1826	(9.) Nut (2 per car)	0.76
,3894	(10.) Washer (2 per car)	0.51
667889	(11.) Spacer sleeve	5.09
665236	(12.) Rubber seal (in flooo)	63.64
653625	(13.) Return spring	Coming Soon

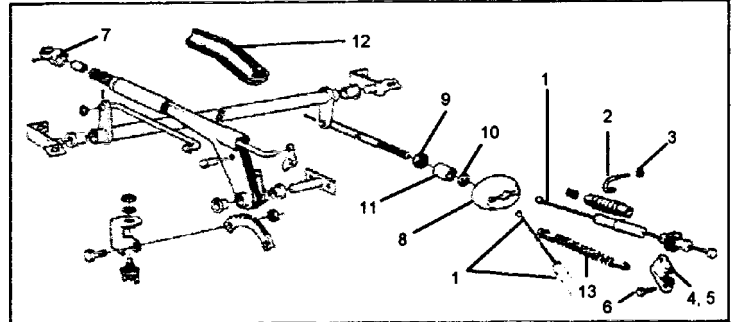

Footbrake system (front), B18 (single circuit)

		<u>Price</u>
670728 (ERX1.)	Brake caliper, exchange reconditioned, lhs	234.18
670729 (ERX1.)	Brake caliper, exchange reconditioned, rhs (NB. Core charge is now sek 500 per piece)	234.18
276489	(2.) Repair kit for 2 calipers (genuine)	123.45 pair
276489-R	Repair kit for 1 caliper (repro.)	35.64 pc
667593	(3.) Piston, small (genuine) (2 per caliper)	86.55 pc
667593-R	(3.) Piston, small (2 per caliper)	28 pc
667592	(4.) Piston, large (genuine) (1 per caliper)	45.82
667592-R	(4.) Piston, large (1 per carper)	31.82
664823	(5.) Bleed nipple	4.58
656456	(6.) Dust cover	1.53
270489-1	(R) Overhaul kit (for 2 calipers) (contains pistons, seals, bleed nipples)	221.45 kit
668905	(7.) Bolt for fitting of caliper (2 per caliper)	4.58 pc
669012	(8.) Lock washer (with bendable tabs)	10 pc
j8333/34	(9.) Backplate, LHS/RHS	124.73 pc
666529t28	(10.) Bracket, later type, lh/rh (second-hand only)	67.45 pc
FK-008	(11-14) Fitting kit, backplate to stubaxle	8.91/side
666525	(15.) Brake disc, genuine (fits from ch # 7000-) (fits earlier cars provided caliper brackets (no. 10) are changed to later type)	406.00
666525-1	Brake disc, without hub	162.91
667238	Hub for brake disc (genuine)	Call
657874	(16.) Wheel bolt	11.45
87699	Wheel nut	2.55 pc
275819	(17.) Brake pad set for 2 calipers, to ch. 6999 (please check calipers haven't been updated!!!)	99.27
270987	(17.) Brake pad set, both calipers, ch 7000-	61.09
272691	(18.) Fitting Idt, for both calipers	7.64
653238	Pedal rubber (R)	11.45
664800	(19.) Brake hose, genuine	47.09
955858	(20.) Nut (2 per hose)	1.27 pc
955950	(21.) Lock washer (2 per hose)	0.51 pc

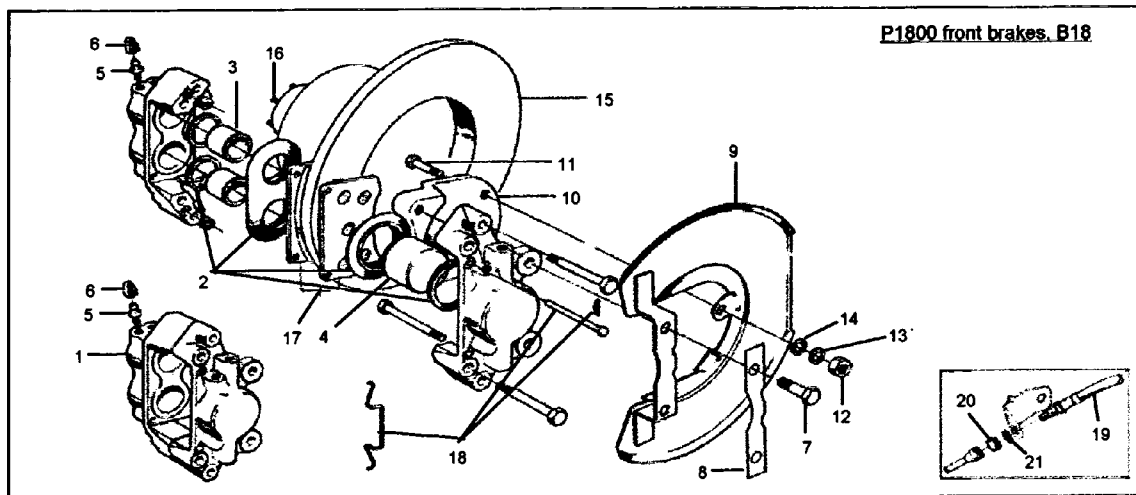

670404	(11.) Wheel cylinder, 7/8"	44.55	671202	(11.) Lever, lhs	90.36
276407	(2.) Repair kit, genuine (even for cyl. 662513)	38.18 pair	668667	(12.) Brake adjuster unit	67.45
276574	(2.) Repair kit, gen. (cyl. 671207, june '64-june65)	45.82 pair	955846	(13.) Nut (for brake adjuster)	0.51
656455	(3.) Bleed nipple for cylinders	7.13 pc	940155	(14.) Lock washer	0.51
656456	(4.) Dust cover for nipple	1.53	673797	(15.) Brake drum, gentrine (with hub)	327.09
662518	(5.) Screw, cylinder to backplate	6.11	673797-1	Brake drum (without hub)	162.91
940155	(6.) Lock washer	0.51	654490	(16.) Wheel bolt	11.45
271814	(7.) Brake shoe set (genuine)	70.00	87699	Wheel nut	2.55
271814-1	(7.) Brake shoe set (non-genuine)	57.27	153031	(17.) Castle nut for drum	22.91
273171	(8.) Fitting kit (genuine)	28 axle	191174	Split pin	0.51
273171-1	Fitting kit, with return springs (8+9.)	24.18 axle			
671201	(10.) Link	18.33			

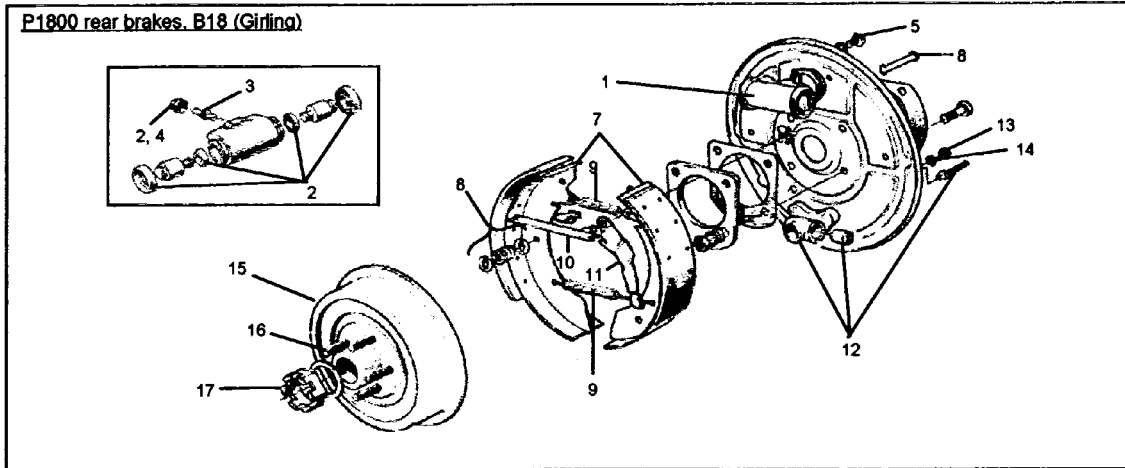

664800	(1.) Brake hose, front (genuine)	47.09	87696	(10.) Three-way union	30.55
670201 (G)	(2.) Brake hose, rear (Girling)	28.00	18363	(11.) Clamp (now 18355)	6.36
955858	(3.) Nut	1.27	670921 (ER)	(12.) Brake servo, Girling original (exchange (We must receive your old servo before shipping) Repair kit, Girling servo (with instructions)	1011.82
955950	(4.) Lock washer	0.51	276556		180.73
18651	(8.) Copper washer for rear hose	1.02 pc	671056/57	Air filter/cover, Girling servo (screw fixing)	36.91 set
665038	(6.) Rubber grommet	NLA	669590	Valve on T-piece (on side of alum. hsg.)	35.64 pc
18335	(7.) Clamp (single), for brake pipes	5.09	942464	Servo hose	Call
121572	(8.) Clamp (double), for brake pipes	8.91	L-276	Lockheed servo ldt	661.81
9)665	(9.) Screw	1.02	VH 44	PBR servo kit	661.81

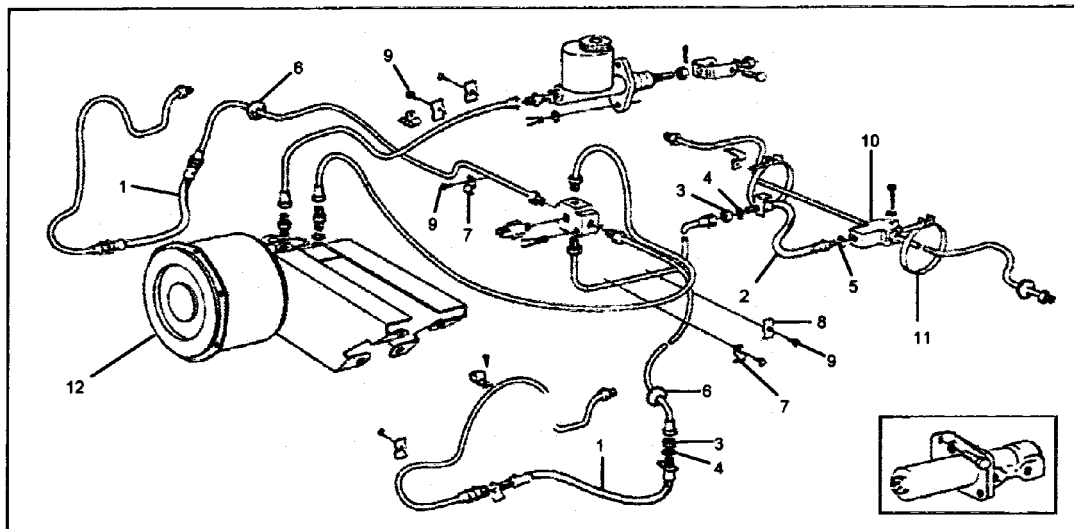

Fitted to cars exported mainly to the USA

A Note about this System

This particular system was an oddball one, as far as we can see hastily put together by Volvo in late 1967 to comply with US safety and local content regulations, which must have come i~~ play at some stage during that year. The system uses Girling disc brakes at the front, coupled with Wagner Lockheed drum brakes at the rear, and with the peculiarity of a Girling remots brake servo which operates on the front wheels only. The master cylinder is of the dual-circuit tandem type, made especially for Volvo by Wagner Lockheed. Repair kits for the originalS are available. We are now also able to offer a new complete (repro) cylinder (less the reservoir).

Brake master cylinder

672825	(1.) Brake master cylinder (R)	534.55
273076	Repair kit, odg. VYL cyls (genuine) with piston	118.36
273076-1	Repair kit (rubbers only) (R)	31.82
678237	(2.) Rubber sleeve (2 per -0	11.45
18677	(3.) Washer (gasket)	3.05
681659	(4) Strainer	20.62
940135	(5.) Bolt	0.76
955949	(6.) Lock washer	0.51
672917	(7.) Yoke (not for automatic cars)	19.09
907824	(8.) Spit pin	0.25
955847	(9.) Nut	0.51
955921	(10.) Spring washer	0.51

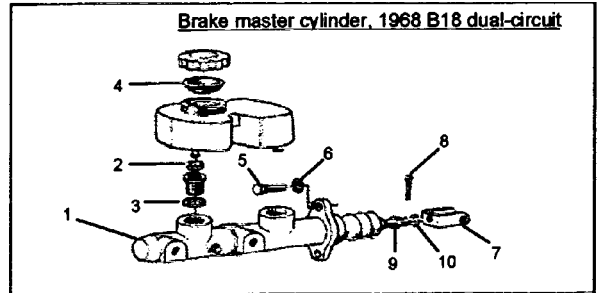

Front brakes: See „Footbrake system, front B18” - Page 24

Handbrake System: See Page 24

Rear Drum Brkes - 1968 Dual-Circuit

667166	(1.) Wheel cylinder	66.18
273024	Repair kit (with return spring) 95	
87462	Bleed nipple, on wheel cylinder	3.82
659676	(2.) Pushrod (2/cyl.)	7.13 pc
955512	(3.) Screw, wheel cyl. to backplate	0.51
955920	(4.) Lock washer	0.51
271813	(5.) Brake shoe set (genuine)	72.55
659663	(6.) Guide pin, for brake shoe fitting	3.82
659664	(7.) Spring clip (old-style genuine - the best!)	4.58
659663164-1	Guide pin and clip set, for one axle	24.18 set
69916	(8.) Guide washer (arrow must point forwards)	7.64
659670(B)	(9.) Retainer (second-hand only)	7.64
9672	(10.) Rubber plug, for adjuster hole	10
-13172	Guide pin ldt: 659663/64-1 + 669916 + 659672	44.55
667160	(11.) Return spring, upper	6.36 pc
659668	(12.) Return spring, lower	6.36 pc
667160-1	Return spring set (6 pcs.)	24.18 set

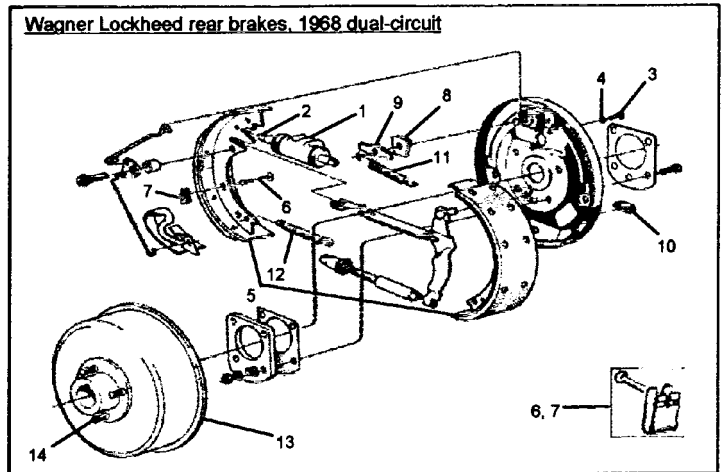

673797	(13.) Brake drum, genuine (with hub)	327.09
673797-1	Brake drum (without hub)	162.91
654490	(14.) Wheel boft	11.45
87699	Wheel nut	2.55

Brake Servo (booster): See Page 25

Brake Hoses, Pedal rubber, Brake light switch, Reduction Valve

664800	Brake hose, front (genuine)	47.09	87696	Three-way union, on rear axle casing	30.55
955858	Nut for 664800	1.27 pc	121585	Band clamp, around axle	Call
955950	Lock washer for 664800	0.51 pc	679364-R	Brake light switch	16.55
670201 (G)	Brake hose, rear (Girling)	28.00	653238	Pedal rubber (R)	45
955858	Nut At front of rear hose	1.27			
955950	Lock washer	0.25			
18651	Copper washer, at rear of rear hose	1.02			

Brake Master Cylinder and Servo

		Price
673766	(1.) Brake master cylinder, genuine	325.82
273125	(2.) Repair kit (includes pistons)	117.09
273125-1	Repair kit, non-gen. (rubbers only) (R)	31.82
6809M	(3.) Rubber ring	8.91
955782	(4.) Nut	0.51
955921	(5.) Spring washer	0.51
673767	(6.) Brake fluid reservoir	123.45
678237	(7.) Rubber grommet (2 per -0)	11.45
681659	(8.) Strainer, under filler cap	20.62
673768 (ERX9.)	Brake servo, exchaM rebuilt (Note: we nwst recetve your old unit b we are able to send you a rebuilt one)	3975
1037	Decal (ATE T51) on brake servo	10.18

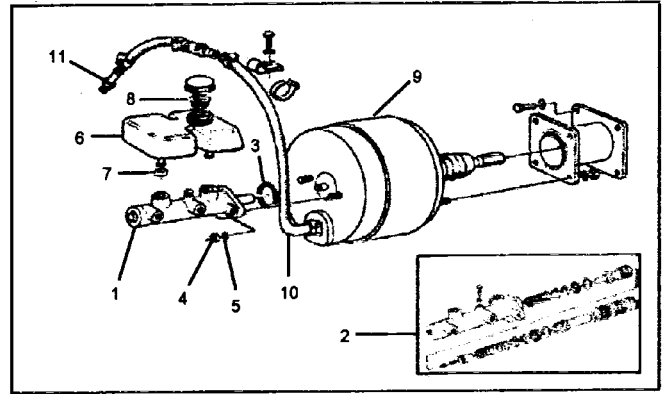

943707	(10.) Servo hose	Call
943199	(11.) Nipple	49.64

Footbrake system, front, Volvo 1800S/E/ES 1969-1973

684432 (ERX)	(1.) Brake caliper, excharm3e reconditioned, lhs	218.91	666176	Pedal rubber (R) (manual g'box)	11.45
684433 (ERX)	(1.) Brake caliper, exchange reconditioned, rhs	218.91	669843-R	Pedal rubber (automatic)	14.00
943506	(2.) Bolt, caliper to bracket (2 per caliper)	5.09	679364-R	Brake light switch	16.55
678142	(3.) Piston (4 per caliper) (genuine)	60.07	666525	(11.) Brake disc, genuine (with hub), 1969	406.00
678142-R	(3.) Piston (4 per caliper) (non-genuine)	30.55	666525-1	Brake disc, without hub	162.91
273071	(4.) Repair ldt (rubber seals) for 2 calipers	157.82 pair	270733	(11.) Brake disc, 1800EIES(ref 682304)	245.64
273071 -R	Repair kit for 1 caliper (non-genuine)	34.36 pc	657874	(12.) Wheel bolt	11.45
678155	(5.) Bleed nipple (3 per caliper)	3.82 pc	87699	Wheel nut, up to 1969	2.55 pc
656456	(6.) Dust cover (incl. in rep. ldts)	1.53	688984	Chromed wheel nut, 1800E/ES	8.91 per pc.
673773	(7.) Backplate, lhs	122.18	688984-20	Chromed wheel nut set, 1800E/ES	142.55 for 20 pcs.
673774	(7.) Backplate, rhs	122.18	671799	(17.) Brake hose, front (4/-)	28 pc
FK-008	(8.) Fitting ldt, backplate to stubaxle	8.91/side	955858	(18.) Nut	1.27
271739	(9.) Brake pad set (for both front wheels)	53.45	942336	(19.) Lock washer	0.51
272691	(10.) Fitting kit (both wheels)	7.64			

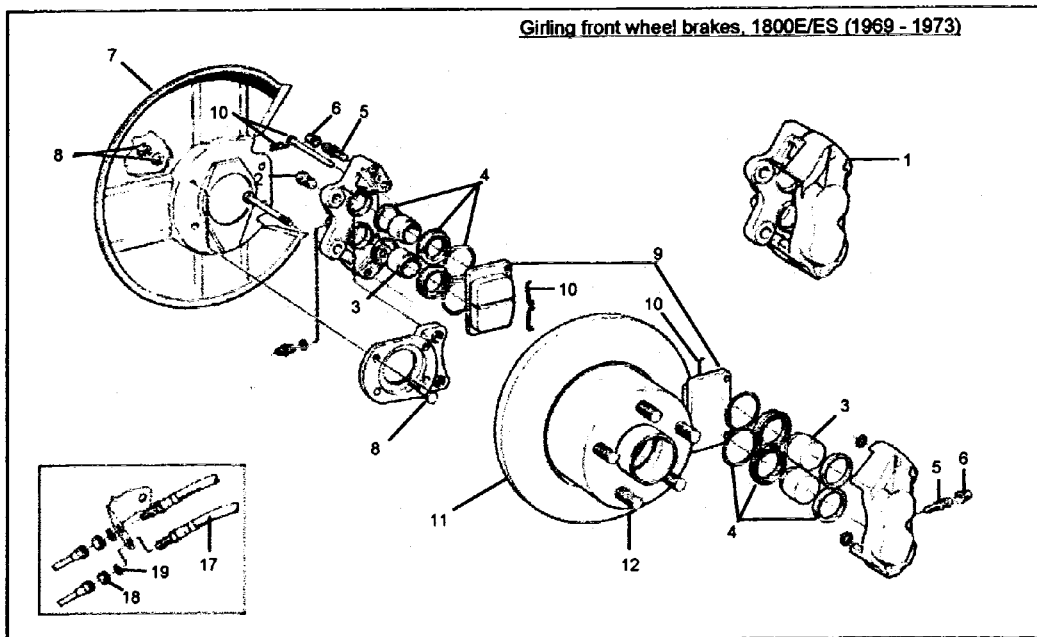

Footbrake system, rear, Volvo 1800S 1969 (B20B)

673731	(11.) Wheel cylinder	44.55
273275	(2.) Repair ldt, genuine, for two cylinders	43.27 pair
273275-R	(2.) Repair kit, repro., for one cylinder	16.55
678155	(3.) Bleed nipple	3.82
656456	(4.) Rubber cover	1.53
271814	(5.) Brake shoe set (1axle) (genuine)	70.00
271814-1	(5.) Brake shoe set (1 axle) (non-genuine)	57.27
273171	(6.) Fitting kit (genuine)	28 axle
273171-2	Fitting kit find. return springs) (6 + 7.)	24.18 axle
673797	Brake drum	327.09
679364-R	Brake light switch	16.55
273090-R	Repair kit, red. valve (2XgL-,t. piston)	42.00
670201 (G)	(8.) Brake hose, rear (2/car)	110 PC.
942336	(9.) Spring washer	0.51
955858	(10.) Nut	1.27

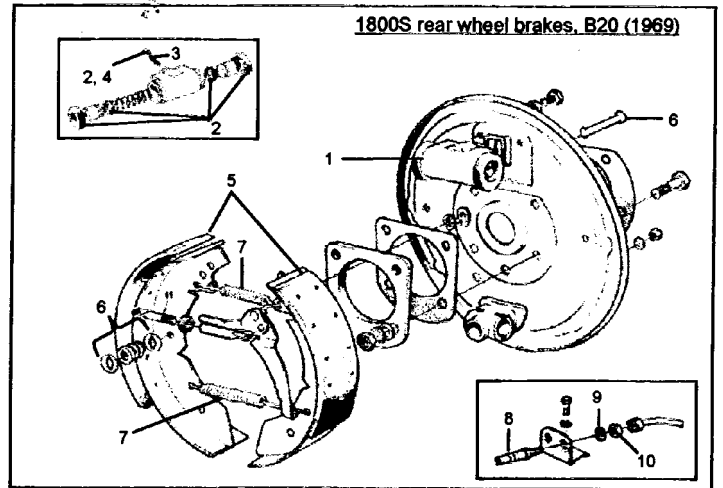

Footbrake system, rear, Volvo 1800E/ES 1970-1973

685324t25	(ER) Caliper, exchange reconditioned Qhrlh)	189.24 pc
943507	(1.) Bolt (2 per caliper)	5.60
685331	(2.) Piston	36.91
678155	(3.) Air bleed nipple	3.82
656456	(4.) Rubber cover Oncl. in repair kit 273114)	1.53
273114	(5.) Repair kit for 2 calipers	82.73
270164	(6.) Brake pad set, genuine	50.91
	(7.) Fitting kit for brake pad (l axle)	Call
270731	(8.) Brake disc	118.36
1206482	(9.) Backplate, lhs	110.47
1206483	(10.) Backplate, rhs	110.47
950045	(11.) Screw	1.02
273090-R	(12.) Repair kit, reduction valve (excls. piston)	42.00
670201	(GX13.) Brake hose, rear (Girling) (2/car)	28 pc
942336	(14.) Spring washer	0.51

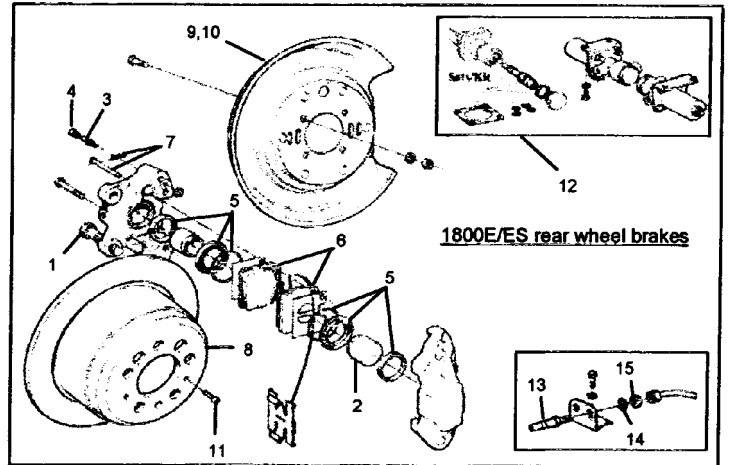

955858	(15.) Nut	1.27
--------	-----------	------

Handbrake system, from 1970

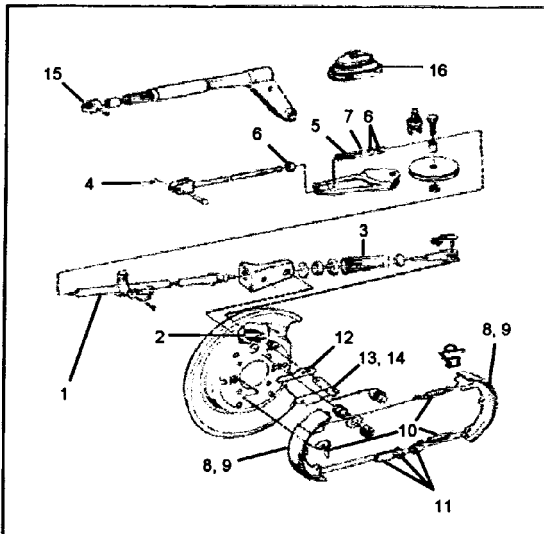

1212342	(1.) Handbrake cable 0 per car)	137.45
688136	(2.) Rubber grommet	21.38
686336	(3.) Return spring	8.15
907824	(4.) Spit pin	0.25
659655	(5.) Spring	6.36
955826	(6.) Nut	0.76
960141	(7.) Washer (Now 976944)	0.51
677530-1	(8.) Handbrake shoe set, l car (early type)	56.00
1212193-1	(9.) Handbrake shoe set, l car (later type)	56.00
FK-681963	(10.) Fitting kit for handbrake shoes, both wheels	24.18
677525	Handbrake adjuster, with sleeve	Call
677528		
677529	(12.) Sea[(l 800E to ch. no. 31456)	11.71
688118	(13.) Lever, lhs	42.00
688119	(14.) Lever, rhs	42.00
660651	(15.) Plastic eyelet on handbrake lever	9.67
665236	(16.) Rubber sealing gaiter, in floor	63.64

664371	(1.) Front wing, lhs	1209.09
664372	(2.) Front wing, rhs	NLA
664373	(3.) Front panel	May be produced - Call!
CM-LP18001	Wheel arch protectors	241.82/pair
664725	(4.) Front rail, under wing/lender, lhs	276.18
664726	(5.) Front rail, under wing/fender, rhs	276.18
664168	(6.) Splash plate, lhs (now 1213717)	NLA
664169	(7.) Splash plate, rhs (now 1213718)	182.00
665716	(7a.) Rubber seal around splash plate	28 pc
664192 (B)	(8.) Bonnet, rust free second-hand	2750
664192 (X)	Repair section for bonnet	Call
664257	Bonnet hinge (2/car)	162.91
669105	(9.) Rubber cushion, from ch. 10200-	7.13 pc
SDD-P18	(10) Bonnet soundproofing sell	104.36
664513	(11.) Bonnet stay: a.) (early) star-wheel type b.) (late) manual type	40.73 38.18
664175	(12.) Ajrintake (left side only is available)	98.00
654067	(13.) Cross-member, under radiatoi	103.09
653309	(14.) Cover plate, on front of crossmember	88.58
653687	(15.) Front chassis outrigger & vMo lack point)	86.55
663884	(16.) Mudflap, front	34.11 pc
663882	(17.) Mudfiap bracket front	36.91 pc
190364	(18.) Screw for mudflap & bracket (5/side)	0.51 pc
192041	(19.) Washer (2 per side)	0.51 pc
664285	(20.) Reinforcing ring, headlarrip	61.09
664246	(21.) Reinforcing ring, indicator	29.27

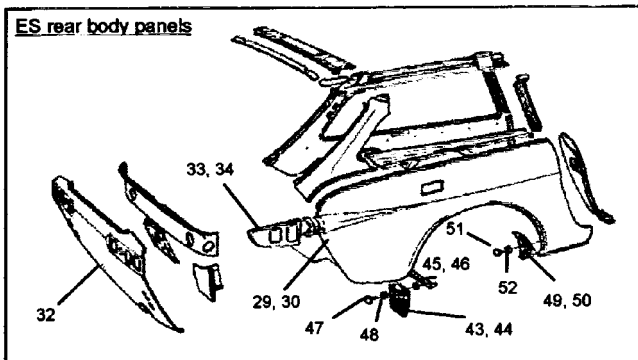
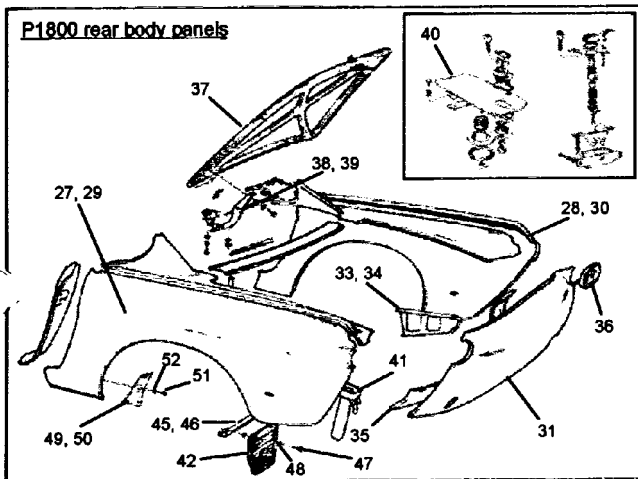
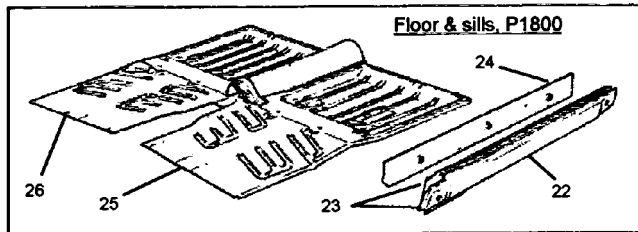
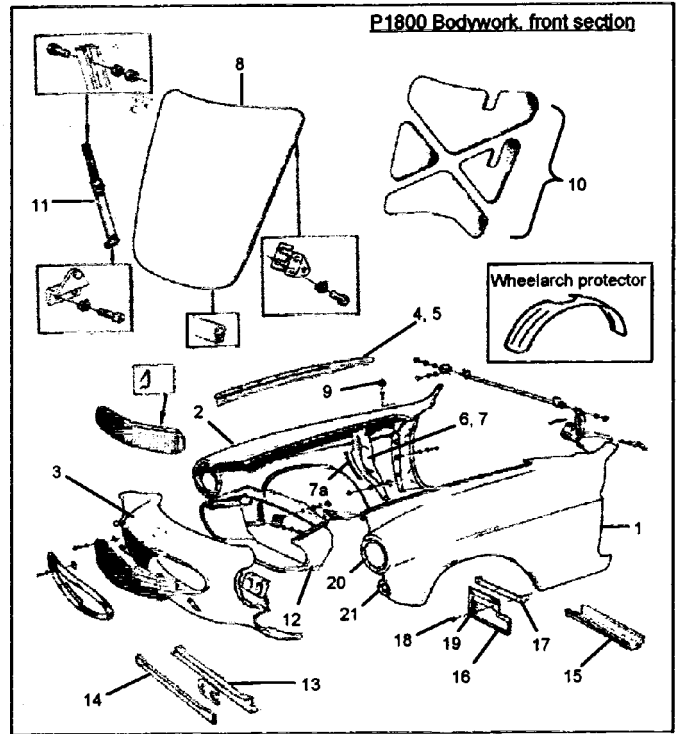

664057/58	(22.) Outer sill panel, lh/rh	241.82 pc
664380/81	(23.) Sill (complete), lh/rh	NLA
664062/63	(24.) Inner sill, lh/rh	239.27 pc
664998	(25.) Floor pan (lh, front section) (R)	220.18
664998	(26.) Floor pan (rh, front section) (R)	220.18
DRSK-P18	Door skin, lh/rh (R)	Call
DRBT-P18	Repair section for door bottom	Call
678127	Reflective sticker on door edge	5.09 pc
664256	Door stop	Call
664279	(27.) Rear wing, lh., up to ch 30DOO	1489.09
664280	(28.) Rear wing, rh., up to ch 30000	1410.18
682231	(29.) Rear wing, lh., from ch 30001 -	1410.18
682232	(30.) Rear wing, rh., from ch 30001 -	1410.18
664000	(31.) Rear panel, P1800IS/E	1221.82
684242	(32.) Rear panel, 1800 ES	1043.64
664170	(33.) Stay plate, left (R)	16.55
664171	(34.) Stay plate, right (R)	220.18
664172	(35.) Stay plate, rear	257.09
664102	(36.) Anchorage plate for rear lamp	24.18
664199	(37.) Bootlid, P1800/S/E	Call
664199 (x)	Repair panel for bootlid	250.73
664730	(38.) Spring for bootlid, P1800IS/E, lh	81.45
664731	(39.) Spring for bootlid, P1800/S/E, rh	81.45
664287	(40.) Filler flap, with hinge, PI 800/S (R)	call
664297-R	(41.) Filler inlet (less pipe) (to order only)	Call
683936	Filler flap, with hinge, 1800E/ES	276.95
663880	(42.) Mudfiap, rear, P1800/S/E	31.56 pc
1211389	(43.) Mudfiap, rear lh, 1800 ES	32.84
1211466	(44.) Mudflap, rear rh, 1800 ES	32.84
663878	(45.) Mudflap bracket, lh rear (now stainless)	24.18
663879	(46.) Mudflap bracket, rh rear (now stainless)	24.18
190364	(47.) Screw for mudflap & stay (3/side)	0.51 pc
960140	(48.) Washer (2 per side)	0.51 pc
669637	(49.) Gravel deflector, lh	23.93
669638	(50.) Gravel deflector, rh	23.93
955120	(51.) Screw for gravel deflector (5 per side)	0.51
955891	(52.) Washer	2

		Price			
668200	Seal behind indicator lamp	42.00	668980 (R)	Seal around door opening, to '69 (felt)	108.18
672146	Bonnet rest seal	42.00	668981 (R)	Ditto, rhs (not plastic but original style M)	108.18
672147	Bootlid seal	75.09	682296 (R)	Door opening seal, E, lh (felt, not pvc)	108.18
673319	Windscreen seal, to 1969, P1800/8	80.44	682297 (R)	Door opening seal, E, rh (felt, not pvc)	108.18
1211949	Windscreen seal, from 1970 (1800E, ES)	80.44	682940/41 (R)	Seal around door opening, 1800 ES Oh/rh)	108.18 pc
665202	Rear side glass seal, lhs	108.18	6689801BIR	10 Use this no. when ordering above seats	
665203	Rear side glass seal, rhs	108.18		(Note: door opening seals now come all felt-covered not pvc (originally Volvo changed from felt to pvc with Intro. of 1800E 1970. You must therefore cut your own 90 degree angles).	
688487 (s/h)	1800 ES rear side glass seal, lhs (used)	NLA	665121	Rubber seal, on bumper iron, front	28.00
688488 (s/h)	1800 ES rear side glass seal, rhs (used)	NLA	665124	Rubber seal, on bumper iron, rear	15.78
668373	Rear screen seal, PI 800IS/E	77.89	665125	Rubber seal, on side iron (Jensen cars)	52.18
683842 (R)	Rear screen seal, 1800 ES	108.18	1213591	Rubber seal on late type bumper iron, lh	65.16
673459	Vent window seal, lhs from ch. 10000-	Soo	1213592	Rubber seal on late type bumper iron, rh	65.16
673460	Vent window seal, rhs from ch. 10000-	127.27	668311	Seal on bumper sections, from 1965	56.00
668258	Scraper seal against door glass	35.64	665046	Seal behind taillamp, P1800/S/E	34.36
664871	Clips for scraper seal (5 per side)	2.04 pc	668116	Number plate lamp seal (not Jensen)	42.76
672152	Door seal (on door), lhs	77.64 pc	665041	Seal behind headlamp bowl, in wing	28.00
12153	Door seal (on door), rhs	77.64 pc	669796	Wiper spindle seal	31.82 pc

GRILLE, BUMPERS, HUBCAPS & WHEEL RINGS, VOLVO P1800

664841 'Newt "Eggbox" grille, Jensen type (aluminium)	725.45	684667	Centre section, rear	493.82
683633 Grille, 1800E 1972, all 1800 ES	445.45	668311	Rubber strip (on corner sections)	56.00
684967 Clips, for 683633 (8/car)	NLA	668312	Metal retainer (under strip)	21.64
273070 Grille surround, P1800/S	(use 273168)	683871 (R)	Rear underrider, 1800 ES	Call
273168 Grille surround, 1800E, 1970 & 1971	890.91	670437 (F;Q)	Black "V" hubcap, '65-69 (chromed steel)	89.09
(comes with rubber seal + fitting kit)			(Note: we cannot give guarantee against rust)	
273201 Grille surround, 1800E '72, all ES	(use 273168)		Wire wheel set (5" x 15")	Call
13319 (P18)	11.96	684001	Wheel rim, 5 1/2" x 15", 1972-73	173.09
665435 Front centre section (Jensen)	395.56	684835	Hub cap (small chrome centre), '72/73	24.18
665478 Rear centre section (Jensen)	395.82	1210343	Emblem (in centre of 684835)	Call
654108 Hub cap ("V"), 6001-12499 (stainless)	149.16 pc	688984	Chromed wheel nut, 1 800E/ES	8.91
654108 (D)	7.64 pc	688984-20	Chromed wheel nut set, 1800E/ES (20 pcs.)	142.55
668326 Bumper corner, front left/rear right	824.47			
668327 Ditto, front right/rear left (from 1965)	824.47			

EXTERIOR TRIM, VOLVO P1800

664622 Front wing moulding, '61266, LHS	now 311.82 each	664738	Petrol flap lock, with chrome housing	72.55
664623 Front wing moulding, '61 --66, RHS	now 311.82 each	668259	Trim strip outside door glass, lhs	123.45
668068 Clips for moulding (5 per side)	6.36 pc	668260	Trim strip outside door glass, rhs	123.45
664624/25 (s/h) Door moulding, curved, '61/66	Call	668258	Door glass scraper seal	35.64
671987/88 Front wing moulding, '67273 (lh/rh)	146.11 pc	664871	Clips for seal/trim strip (5 per side)	8 pc
95384 Clips for later type moulding	1.02 pc	669631	Trim on top of rear wing, LHS	400.91
671981/82 Door moulding, V7-73 (lh/rh)	129.82 pc	669632	Trim on top of rear wing, RHS	400.91
671989/90 Rear wing moulding, '67269 (lh/rh)	129.82 pc	654585	Forward clips, for trim, - 37549 (3 per side)	4.84 pc
685982/83 Rear wing moulding, 70273 (lh/rh)	49.38 pc	672259	Rear clips, coupe - 37549 (2 per side)	7.64 pc
95384 Clips for trim 67273	1.02 pc	672259	Rear clips, 1800E, ch. 37550- (1 per side)	7.64 pc
669261 Front screen trim, LHS	118.36	672259	Rear clips, 1800ES (1 per side)	7.64 pc
669262 Front screen trim, RHS	118.36	940092	Nuts for above	0.51 pc
669328 Rear screen trim (coupe), LHS	NLA	670065	Guttertrim (lhs)	98.00
669329 Rear screen trim (coupe), RHS	129.82	670066	Gutter trim (rhs)	98.00
660151 Junction	25.71 pc	6648W	Junction piece	15.27 pc
664737 Bootlid handle, P1800/S/E	95.45			
664545 Gasket, under handle	5.09			

664493	Front nose badge, to ch 32799 (Could be produced - please register interest on Website)	NLA	670241 (R)	1800 S badge	75.09
665337	Clips for badge Atment	NLA	685811 (R)	Volvo badge (rear), late E/all ES	63.64
675887(R)	Front nose badge, 1800E, ch 32800-37549	63.64	684804(R)	1800E badge	75.09
685946 (R)	Frnt. nose badge, 1800E fr. ch 37550-, all ES	63.64	1211295	1800ES badge, genuine	35.64
191695	Clips for later type nose badges	1.27	688371	Automatic emblem, 1800E	120.91
673702(R)	B20 badge, on grille	58.55	1211078	Automatic emblem, 1800 ES	Call
664617 (R)	Volvo badge on roof pillar (Jensen)	112 pc			
192586	Clips for above badges	NLA			
276375	Volvo letters, rear, up to ch 37549	104.36			
276375(R)	Volvo letters, non-genuine	64.91			

LOCKS, LOCK SETS, MISCELLANEOUS DOOR COMPONENTS, & DOOR GLASS GUIDE SETS

664733	Door lock, with 2 keys	53.45 pc
664733-1	Paired door locks, with 2 keys	96.73 pair
664734	(1.) Bootlid/tailgate lock barrel	53.45
664735	(2.) Patrol flap lock barrel	53.45
664738	(3.) Petrol flap lock, with chrome housing	72.55
---*44736	Lock set comple (4 locks, 2 keys)	133.64
1736-1	Lock set, with 664736 + 664738	165.45
W01 37	(3a.) Key blank (type FP)	12.22
660138	(3a.) Key blank (type FR)	16.55
671319	(3a.) Key blank (type FS)	12.22
664287	(4.) Fuel filler flap, with hinge C61269) (R)	Call
665118	(5.) Rubber seal	24.18
664737	(6.) Bootlid handle (Swedish-made)	95.45
664545	(7.) Gasket, under handle	5.09
664543	(8.) Push button	31.82
664533	(9.) Seal ring on push button	2.55
673261	Ignition lock barrel, 1961-1969 (Neiman)	100.55
673279(B)	Striker plate, LHS, good used	34.36
673280	Striker plate, RHS, new	34.36
673277	Guide, on door, LHS	22.40
673278	Guide, on door, RHS	22.40
665379/80	Door glass elevator, to ch 9999	NLA
669585/86	Door glass elevator, from ch 10000-	NLA
320551	Filler strip, under door glass	12.73 pair

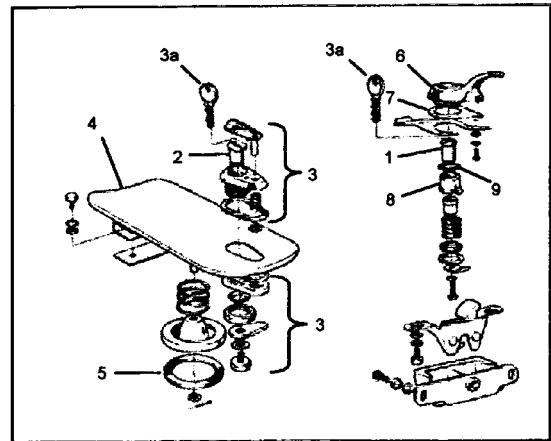

664733	Door lock, with 2 keys	53.45 pc	DGG-P18	Door glass guide kit (for both doors)	96.73 set
664733-1	Paired door locks, with 2 keys	96.73 pair	669405	Qtr. fight frame, LHS, 1800S/E	574.25
664734	(1.) Bootlid/tailgate lock barrel	53.45	683479	(W light frame, LHS, 1800ES	356.36
664735	(2.) Patrol flap lock barrel	53.45	672481	Plastic lock button, vent window, V7- (from ch 21000-)	5.09
664738	(3.) Petrol flap lock, with chrome housing	72.55	664587	Clips, for winder handle, P1 800/S	6.36 each
---*44736	Lock set comple (4 locks, 2 keys)	133.64			
1736-1	Lock set, with 664736 + 664738	165.45			
W01 37	(3a.) Key blank (type FP)	12.22			
660138	(3a.) Key blank (type FR)	16.55			
671319	(3a.) Key blank (type FS)	12.22			
664287	(4.) Fuel filler flap, with hinge C61269) (R)	Call			
665118	(5.) Rubber seal	24.18			
664737	(6.) Bootlid handle (Swedish-made)	95.45			
664545	(7.) Gasket, under handle	5.09			
664543	(8.) Push button	31.82			
664533	(9.) Seal ring on push button	2.55			
673261	Ignition lock barrel, 1961-1969 (Neiman)	100.55			
673279(B)	Striker plate, LHS, good used	34.36			
673280	Striker plate, RHS, new	34.36			
673277	Guide, on door, LHS	22.40			
673278	Guide, on door, RHS	22.40			
665379/80	Door glass elevator, to ch 9999	NLA			
669585/86	Door glass elevator, from ch 10000-	NLA			
320551	Filler strip, under door glass	12.73 pair			

1800 ES TAILGATE HANDLE, LOCK COMPONENTS & GAS STRUT

683228	(1.) Tailgate handle	222.73
664734	(2.) Lock, for glass tailgate	49.64
660137	(3.) Key blank (type FP)	12.22
660138	(3.) Key blank (type FR)	16.55
671319	(3.) Key blank (type FS)	12.22
U3227	(4.) Openerknob	140.00
960220	(5.) O-ring	Call
683229	(6.) Base plate, against glass	NLA
683226	(7.) Lock flap (on inside of glass)	NLA
683223	(8.) Catch (attached to base plate)	22.91
683225	(9.) Spiing, on catch	3.82
684658	(10.) Rubber gasket, on sides (2 per car)	Call
684659	(11.) Rubber gasket, central (2 per car)	Call
688555	Gas filled opener support	70.00
683352	Rubber spacer under strut-to-glass screw	8.91

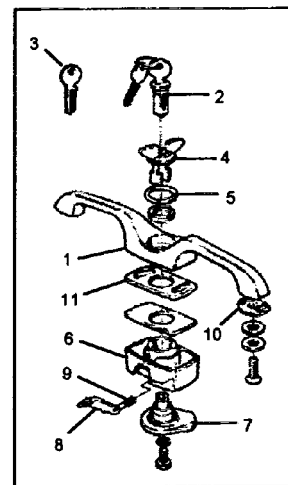

DASHPADDING

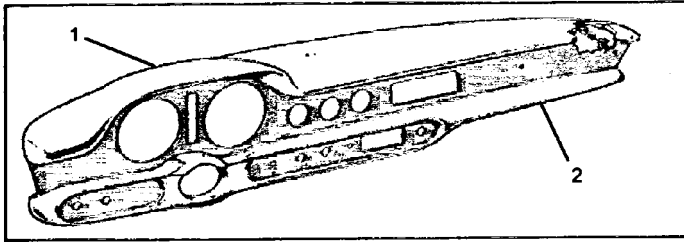

665103	(1.) Dashpadding, upper, lhd	631.27
1212985	(2.) Dashpadding, lower, lhd (ref 665101)	560.00
665103-73 (1 & 2.)	Dashpad (upper & lower), for 1 800ES 73	4300
	Dash caps (for covering existing padding) can be obtained for	
665102/04	Dashpad, upper & lower, for rhd cars	NLA

SPEEDOMETER CABLES, SPEEDO PINIONS, ANGLE BOX, INSTRUMENTS

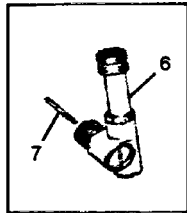
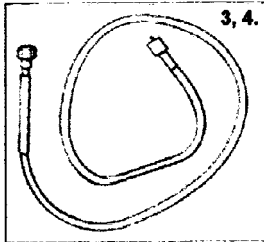

668169	(3.) Speedometer cable, all LHD (+ RHD 1970-)	53.45
668166	(4.) Speedometer cable, RHD 1961-1969	53.45
88273	(5.) Rubber grommet, on cable (from ch. 6001)	3.56
666756	(6.) Angle box (genuine)	194.73
666756-1	(6.) Angle box (VDO)	159.09
666974	(7.) Drive pin, from angle box	7.13
380305-R	Speedo pinion (B1 8), ~6 fthout shaft	123.45
380753	Speedo pinion, B20 (manual gearbox)	111.75
380164	Pinion for automatic, 1800E to ch 37549	25.45
380861	Pinion, automatics, 1800E ch 37550-, all ES	NLA

NOTE: All instruments are sold on an exchange basis: send your old instrument to us before we send out a rebuilt unit. Call us before.

INSTRUMENTS, 1961-1969
(ER = Exchange reconditioned)

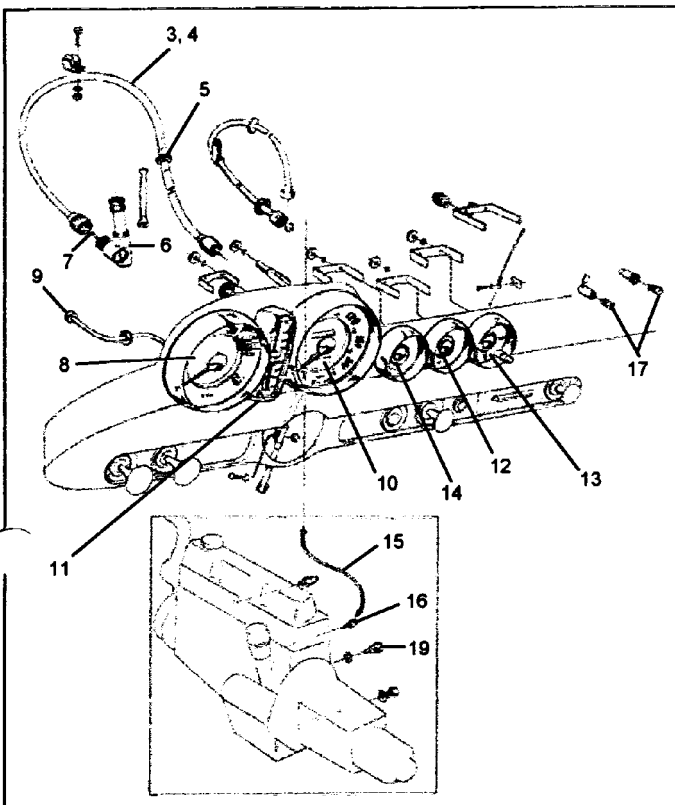

670580 (ER)	(8.) Rev. counter, up to ch 30DOO	1200
664425	(9.) Rubber seal on pipe	8.15
665258	Sender unit, on cars up to ch 9999	NLA
673438 (ER)	(10.) Speedometer, miles	1200
673439 (ER)	(10.) Speedometer, km	1200
	Chrome bezel on Speedo and rev counter can be produced	Call
665259(ER)	(11.) Water and oil temperature gauge (Swedish)	445.45
665260 (ER)	(11.) Water and oil temperature gauge (English)	427.64
664642 (ER)	(12.) Fuel gauge (Swedish text)	225.27
665262 (ER)	(12.) Fuel gauge (English text)	225.27
664644 (ER)	(13.) Clock (exchange rebuilt - Quartz funoon)	604.55
664643 (ER)	(14.) Oil pressure gauge (Swedish text)	222.73
665261 (ER)	(14.) Oil pressure gauge (English text)	222.73
418661	(15.) Flexi hose	104.36
16218	(16.) Elbow union	22.91
277706	(17.) Bulb (8 per car)	3.31 pc
	Chrome bezel (on clock as well as all small gauges)	325

INSTRUMENTS, 1970-1973

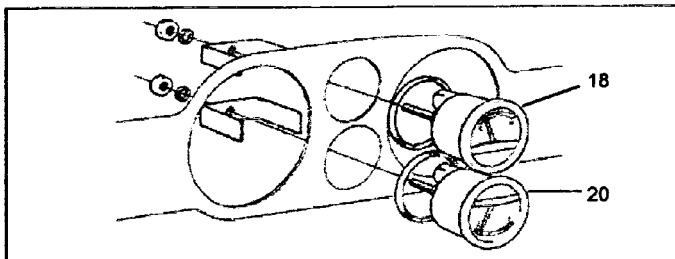

682159 (ER)	Rev. counter	305.45
664425	Rubber seal, on pipe	8.15
1212587 (ER)	Speedometer, km	305.45
1212588 (ER)	Speedometer, miles (Conversion of mph gauges to kph now possible - please call)	305.45
682163 (ER)	(18.) Water temperature gauge	222.73
683299	(19.) Temperature sender unit, water	47.09
682162 (ER)	(20.) Oil temperature gauge	216.36
683298	(19.) Temperature sender unit, oil	53.45
682160 (ER)	Oil pressure gauge	216.36
419860	(15.) Flexi hose for gauge	104.36
419834	(16.) Elbow union (twin outlet)	Call
682161 (ER)	Fuelgauge	220.18
682158 (ER)	Clock(later = 1212961)	Call

		Price			Price
673451	(1.) Heater control valve	208.73	683440	(15.) Ventilator grille, internal, 1800E	34.36
659357	(2.) Rubber seal	6.11			
955126	(3.) Screw C21valve)	0.51 pc	941424	(16.) Defroster hose (2 m per car)	30.55 pc
93963	(4.) Rubber plug (2 per car)	7.13 pc	418628	(17.) Water return pipe, B1 8 C61 264)	Call
82429	(5.) Rubber button (8 per car)	2.5 pc	419414	(17.) Water return pipe, B18 C65-168), B20 (LHD)	Call
40136	(6.) Grommet (for cable) (- ch 2139)	3.82	419746	(17.) Water return pipe, B20 (RHD)	Call
				We offer pipe 419331 with a slightly different angle at the heater end - 240 kronor	
658722	(7.) Sponge seal for defroster flap	10.18	671436 (B) (11 8a.)	Fan motor (second-hand, late type)	
658728	(8.) Sponge seal for heater flap	10.18			
661546	(9.) Heater core	Call			
673707	(10.) Heater hose, long type (former 661560)	24.18	955136	(19.) Screw (9 per car)	0.76 pc
673706	(11.) Heater hose, from valve (former 661551)	17.82			
673705	(12.) Heater hose, from core (former 661552)	16.55	661063	(20.) Drain hose, under heater unit	3.82
6737051617-1	*Set with all 3 hoses	45.82 set	955137	(21.) Screw (8 per car)	0.25
951789	(13.) Hose clamps (blue painted housings)	3.05 pc	673472	(22.) Decal, heater instruction (not ES 1973)	11.45
	*Set with all 6 heater hose clamps	15.27	1214276	(22.) Decal, heater instruction (ES 1973)	11.45
683441	(14.) Ventilator grille, on rear wing, 1800E/ES	21.64	662968	(23.) Seal for ventilator intake	23.93
191695 (14a.)	Starlock washer	2.55			

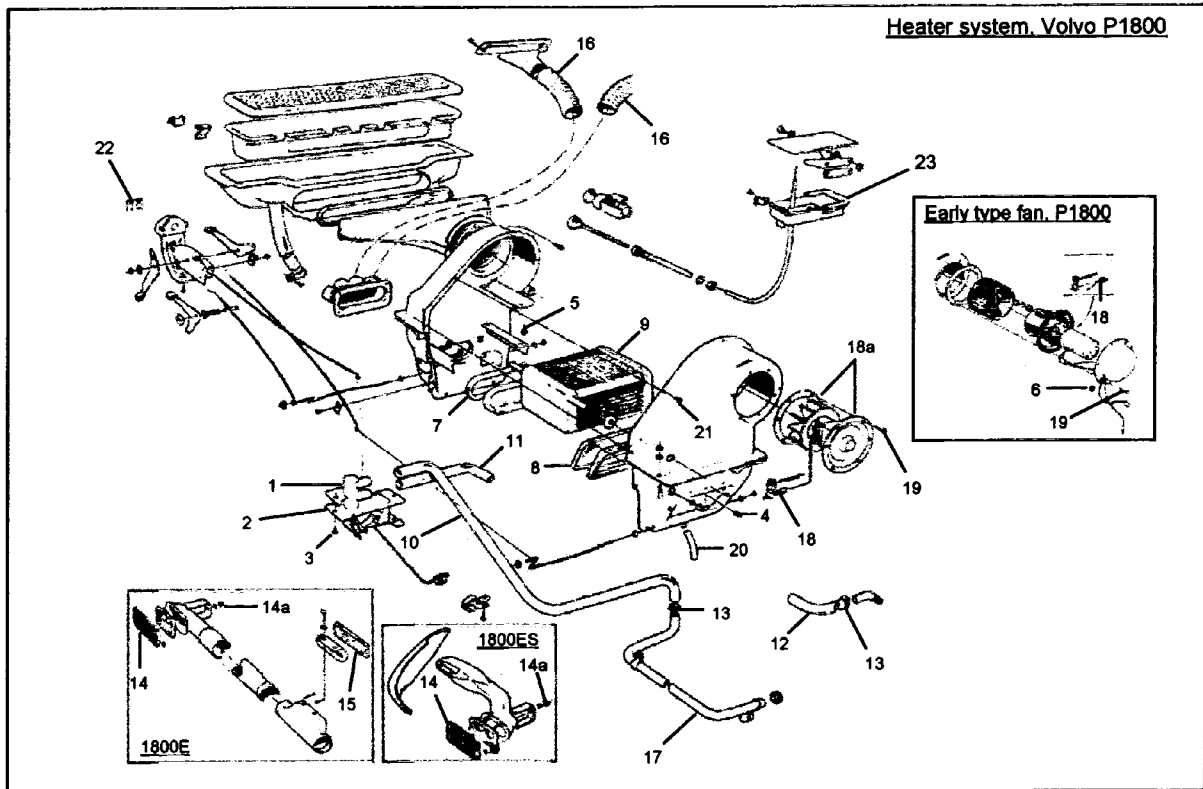

281497 Door mirror (original fitting/option 1968-72), arm attached
281498 to front of base, with threaded studs through door panel
(First introduced during 1968 - replaced by 276614 in '73)

Possible to remanufacture, but subject to demand - let us know.

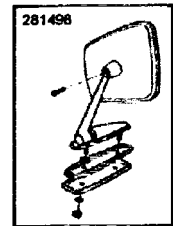

276614 Current genuine door mirror, with arm fixed
to rear of base, blue-tinted flat glass 117.09 la
(First introduced as replacement for 281498 in 1973)

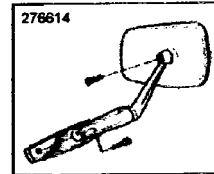

CVA-619F Cone-shaped racing mirror (chromed) flat glass 72.54
CVI-619C Cone-shaped racing mirror (chromed) convex glass 77.63

(Note! Cone-shaped mirror in aluminium also obtainable - Please call

277521 (RP) Wing mirror with round head flat glass 112 pc.
V?S21 Wing mirror (round head)

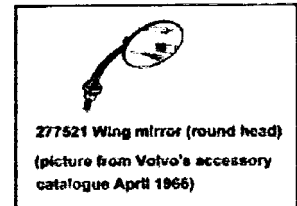

INTERIOR TRIM PARTS, VOLVO P1800 & 1800 ES

665116	Spare wheel cover	112.81	670014	Retainer for sun visors, 1964-1969	31.18
670288-1	Luggage compartment rear panel, lhs Ditto, rhs (NB. State whether Ditto, rear	169.27/set 1800 E or ES	664709	Sill step plate (L & R) Coming soon	
669776-80 (S) 671118 (M)	Webbing, front seat bottom, 1964-1971 Webbing, as above but sold by the meter	980.25seat 12.47 per meter	664609/10 (R)	Carpet retainer strip (UR), with curve	120.90 pair
665117 (R) 684491 (R)	S-Luggage compartment mat, similar to original EJ but without original style border	113.27	687712	Ditto, heated & tinted (replaces 684216)	710.18
671261	Rubber plug, for firewall mat (6/car)	2.54 PC.	668418	Interior light lens, 1964-1972	38.18

WINDSCREENS: HEATED REAR SCREENS, VOLVO P1800 & 1800 ES

(Please note: most glass can be transported anywhere, worldwide, but these items will incur extra packing charges. Please call for details.)

683894	Front windscreen, clear	366.54	668049	Rear screen, rear, P1 800/S/E	Call
683726	Front windscreen, green tint	392	673683	Ditto, heated, rear	710.18
683727	Front screen, green top-tint	Call	685866	Ditto, 1800E C72), all ES (L & R)	call
683728	Front screen, blue top-tint	418.02	683529	Tailgate glass, tinted, heated, 1800 ES	836.38
669405(B)	Complete used vent window w. frame (s/h), 1964 1 Q to 1972 (E)				381.81

2001 91.64	Haynes Workshop manual for Volvo Amazon/1800 series	
2003	Essential Volvo 120 series by Anders Ditlev Clausager	73.82
2005	Volvo P1 20 - The Amazon Series by Dieter Gonther & Walter Wolf	70.00
2006	B18 Workshop manual (copy)	118.36
2007	1800 E/ES Workshop manual, 1972 (copy)	118.36

SPARE PARTS CATALOGUES (VOLVO)

212121	Volvo Spare Parts catalogue, Volvo P1800 (B18 1961-1968)	106.91
212123	Volvo Spare Parts catalogue, Volvo P1800 (1320 1969-1973)	106.91
2008	Volvo fast moving parts catalogue for Amazon, PV/Duett, 140/160 1970	24.18

STICKERS AND DECALS

1006	B1 8B/D Air filter 1961-1966 LHD (AC) 73606	5.09 pc
1007	B18B/D, Air filter 1961-1966 RHD (Cooper. 667583)	8.91 pc
1008	B18 Charging regulator (Bosch 12v)	5.09
1009	B18 Ignition coil (yellow)	5.09
1010	B18B/D Air filter C67268) LHD & RHD 672280/81	8.91 pc
1011		
1012	B1 8 Ignition coil (white, '67268)	5.09
1013	B 18 Radiator sticker	5.09
672765	B18/B20 Alternator warning (from 67 GT, 121/122 '68-)	16.55
1014	B20 Ignition coil (green, '69-70)	6.36
1015	1320/1330 Valve cover sticker ("Check belt tension acc to")	11.45
1016	B20 Radiator sticker ("Filled with genuine Volvo coolant")	11.45
1017	TUDOR Safety Sweden (old batteries)	11.45
678127	Reflector sticker on door edge	5.09 pc
1018	Do not open See Instruction book (radiator cap, '67-70)	6.36
1019	Fill cooling system here (expansion bottle cap '67-70)	6.36
1020	A Product of Superb Swedish Engineering (back window)	22.91
1021	H sticker, for "högertråk", when Sweden changed over in '67	16.55
1022	Volvo Rally - European Champion 1963 & 1964	11.45
1026	Bosch Volvo IrW, on alternator (Amazon, 140, P1800)	45
1029	Brrrrrrrrrrrrrr" Air condition decal	so
673472	Heater control (Mgj ES 1973)	11.45
1214276	Heater control (ES 1973)	14.00
1031	Shut Carefully etc (1 \$00 ES tailgate sticker)	45
1037	Decal (ATE T51) on brake servo	40